

INNOVATION • DEDICATED • SERVICE • WIN-WIN

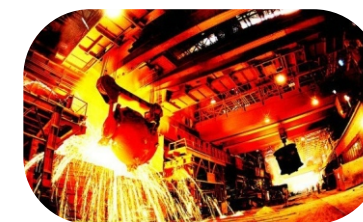

Product Selection Manual

Innovation Dedicated Service Win-win



Website



Face Book

202308(V1.8)

About Us

FRECON Electric (Shenzhen) Co, Ltd. is a national key high-tech enterprise, a dual-soft enterprise in Shenzhen, and a professional company in the fields of industrial automation, high efficiency and energy saving, and green new energy. We have more than ten years of experience in the development and application of frequency converters, servo drives, energy-saving control cabinets, industrial robots, solar inverter systems, electric vehicle drive and control systems. The product power range covers 0.2kW~1MW, and the products are in EMC and safety regulations. All meet the requirements of the EU CE Directive.

Obtained more than 40 patents and copyrights for inventions, utility models, appearances, and software works. The quality system strictly complies with the ISO9001:2015 standard. Products are widely used in equipment manufacturing and energy-saving renovation projects, mainly involving elevators, petroleum, chemical, steel, ceramics, air compressors, textiles, wire drawing machines, machine tools, solar energy and many other fields.

FRECON Electric (Shenzhen) Co., Ltd. has seven regions in East China (Wuxi), South China (Shenzhen), North China (Shijiazhuang), Northeast (Shenyang), Southwest (Chengdu), Northwest (Xi'an), Central China (Changsha), etc. The logistics center has 12 offices nationwide, and has established a nationwide logistics and service network. There are joint insurance centers and distribution networks in more than 70 countries including Australia, Poland, Spain, South Africa, Russia, India, and Vietnam.



Service Network

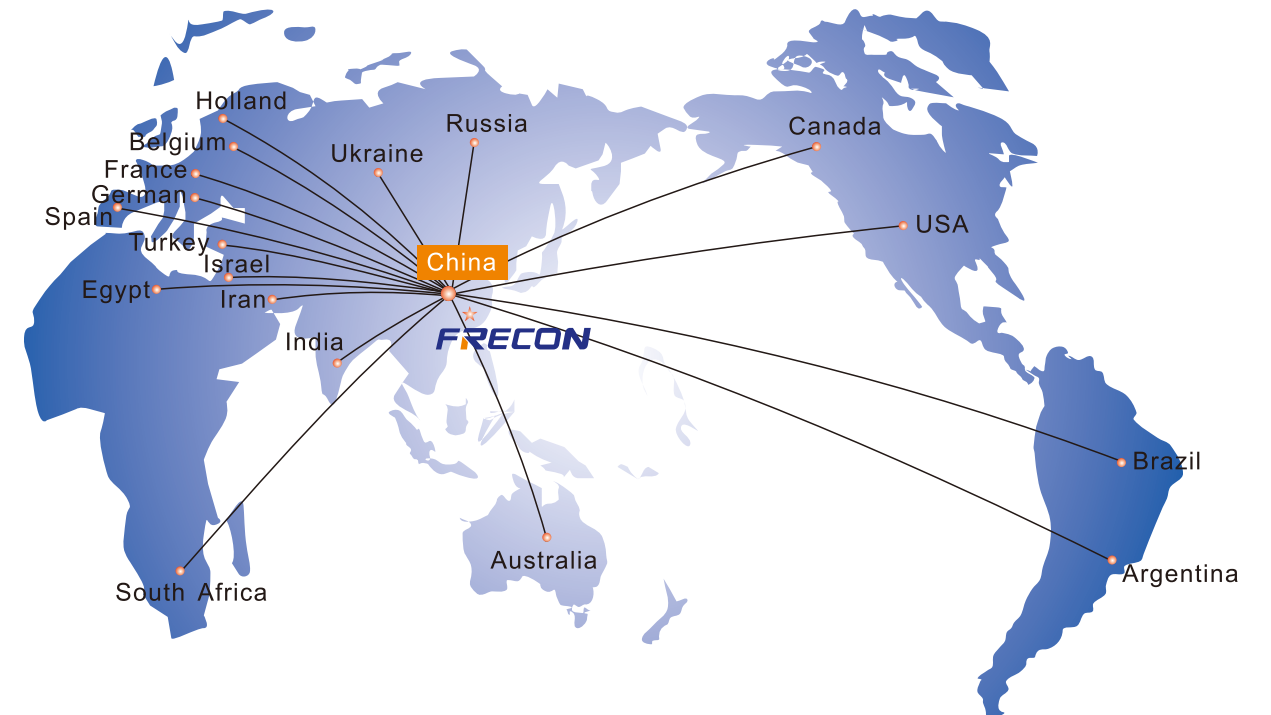

Company Honor



China's leading brand and solution provider

FRECON Product Family

Electric Drive

Industrial Control

New Energy



CONTENTS

◎ About us	01/02
◎ General Purpose Inverter	05/31
FR150A Series Multifunction Inverter	
FR500A Series Vector Control Inverter	
FR510A Series Close Loop Inverter	
FR30 Series High Performance Inverter	
FR600 Series Medium Voltage Inverter	
FR580 Series IP65 Inverter	
◎ Special Purpose Inverter	32/39
SY380 Series Voltage Boost Inverter	
FR500H Series Multi-Pump Constant Pressure Inverter	
FR500D Series Special Purpose Inverter For Elevator	
FR500S Series High Frequency Special Purpose Inverter	
FR500L Series Wire Drawing Machine Special Purpose Inverter	
FR500KFJ Series Open-Frame Special Purpose Inverter	
IF500 Series IP65 Industrial Fan Inverter	
◎ Servo Drive System	40/46
SD300 Series Servo Drive system	
◎ New Energy	47/60
PV150A&500 Series Solar Pump Inverter	
PV580 Series IP65 Solar Pump Inverter	
SP500 Series Hybrid Off-Grid Solar Inverter	
SP520 Series Hybrid Off-Grid Solar Inverter	
◎ PLC&HMI	61/67
PL10 Series PLC	
HK Series HMI	
◎ Soft Starter	68/71
RQ100(A) Series Digital Soft Starter	
RQ100(B) Series Digital Soft Starter	
◎ Optional Accessories	72/76

General Purpose Inverter



- FR150A Series Multifunction Inverter
- FR500A Series Vector Control Inverter
- FR510A Series Close Loop Inverter
- FR30 Series High Performance Invertel
- FR600 Series Medium Voltage Inverter
- FR580 Series IP65 Inverter



FR150A Series Multifunction Inverter



Single Phase
220V : 0.4~2.2KW
Three Phase
380V : 0.75~160KW

General Purpose Inverter

Applications

FR150A series multi-functional Inverter is a product developed on the latest technology platform of FRECON, with advanced control modes for high torque, high precision, high reliability, and wide-speed drive. The FR150A features ideal for equipment matching, engineering reconstruction, automation control and other special industry applications.



Suitable for various types of motors

➤ Standard application wiring

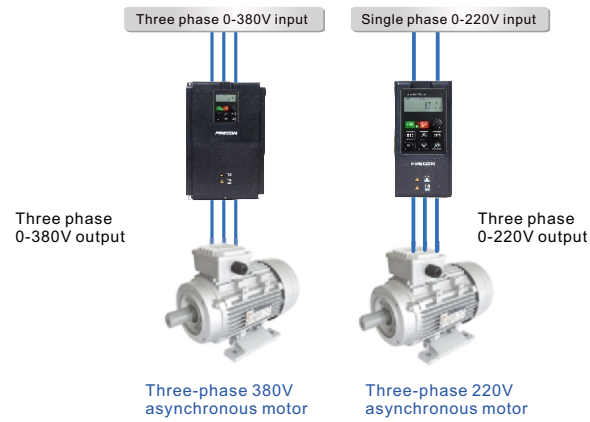

➤ Special application wiring

✕Please contact factory if using below application wiring

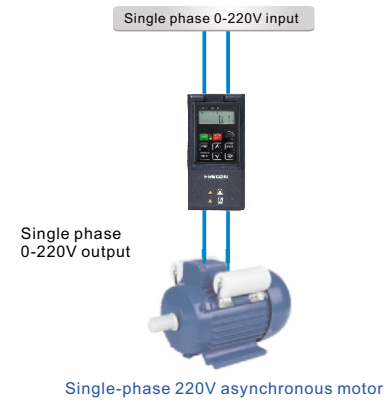

Leading Technology Platform and Optimized Structural Design

➤ Small size, compared with the previous generation of products with the same power, it greatly saves installation space and facilitates the layout of electronic control devices; for the whole series, the maximum installation area is reduced by 40%, and the volume is reduced by 50%.

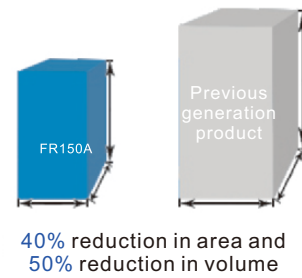

Common DC Bus

➤ Multiple FR150A units can be connected in parallel to share regenerative braking energy, thus the power of braking resistor can be reduced or cancelled.

Rich protection functions

➤ Comprehensive protection to ensure reliable operation

Built-in RS485 communication (Modbus)

➤ RS 485 terminals, support standard Modbus RTU communication for system integration

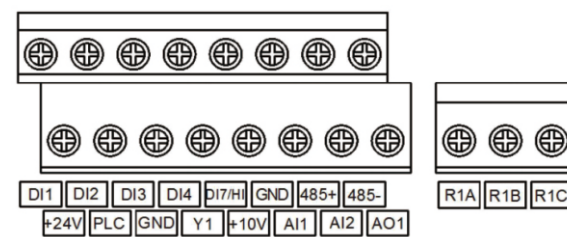

Model No. And Electric Spec

FR150 A -4T-0.7B

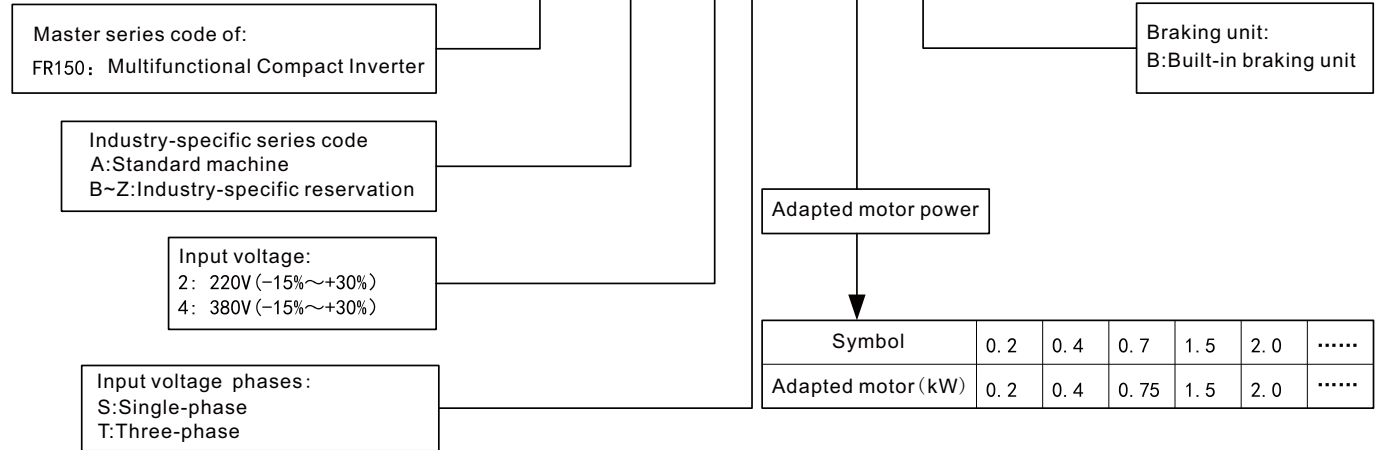

Inverter Model	Power Capacity (KVA)	Rated Input Current(A)	Rated Output Current (heavy load) (A)	Rated Output Current (light load) (A)	Adapted Motor	
					kW	HP
FR150A-2S-0.2B-H	0.5	4.9	1.6	2.5	0.25	0.25
FR150A-2S-0.4B-H	1.0	6.5	2.5	3	0.37	0.5
FR150A-2S-0.7B-H	1.5	9.3	4.2	4.6	0.75	1
FR150A-2S-1.5B-H	3.0	15.7	7.5	8.5	1.5	2
FR150A-2S-2.2B-H	4.0	24	9.5	10.5	2.2	3
FR150A-4T-0.7B-H	1.5	3.4	2.5	3	0.75	1
FR150A-4T-1.5B-H	3	5	4.2	4.6	1.5	2
FR150A-4T-2.2B-H	4	5.8	5.5	6.5	2.2	3
FR150A-4T-4.0B-H	6	11	9.5	10.5	3.7、4	5
FR150A-4T-5.5B-H	8.9	14.6	13	17	5.5	7.5
FR150A-4T-7.5B-H	11	20.5	17	20	7.5	10
FR150A-4T-011B-H	17	26	25	32	11	15
FR150A-4T-015B-H	21	35	32	37	15	20
FR150A-4T-018B-H	24	38.5	37	45	18.5	25

Inverter Model	Power Capacity (KVA)	Rated Input Current(A)	Rated Output Current (heavy load) (A)	Rated Output Current (light load) (A)	Adapted Motor	
					kW	HP
FR150A-4T-022B-H	30	46.5	45	49	22	30
FR150A-4T-030B-H	40	62	60	75	30	40
FR150A-4T-037B-H	57	76	75	82	37	50
FR150A-4T-045-H	69	92	91	112	45	60
FR150A-4T-055-H	85	113	112	134	45	60
FR150A-4T-075-H	114	157	150	168	75	100
FR150A-4T-090-H	134	186	176	210	90	125
FR150A-4T-110-H	160	552	210	253	110	150
FR150A-4T-132-H	192	260	253	304	132	175
FR150A-4T-160-H	231	310	304	340	160	210

Product Installation Dimensions Drawing

➤ (0.2~22kW) Installation size

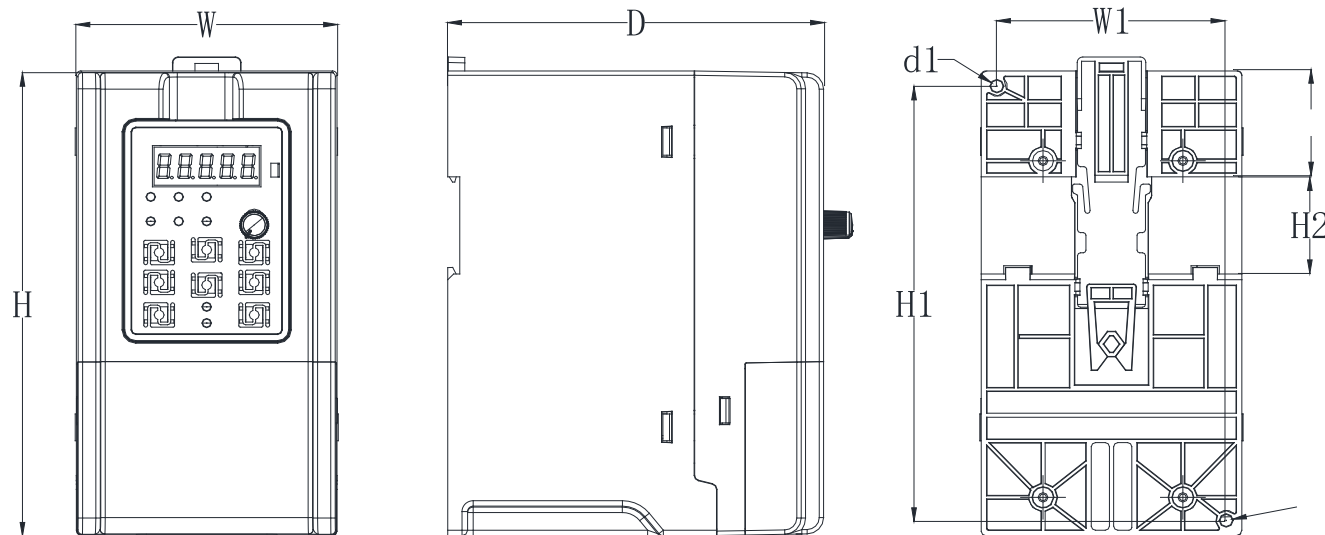

Product Specifications

Item	Specification
Input Power	Rated Input Voltage (V) Single-phase 220V (-15%~+20%) Three-phase 380V (-15%~+30%)
	Rated Input Frequency (Hz) 50Hz/60Hz, ±5%
Output Power	Rated Output Voltage (V) 0~Rated input voltage, Error<±3
	Rated Output Frequency (Hz) 0.00~600.00 Hz, unit 0.01Hz
Control Characteristics	Control Method V/F control ; Sensor-less vector control 1 ; Sensor-less vector control 2
	Speed Range 1:50 (V/F control) ; 1:100(sensor-less vector control 1) ;1:200(sensor-less vector control 2)
	Speed Accuracy ±0.5% (V/F control) ; ±0.2 %(sensor-less vector control 1 & 2)
	Speed Fluctuation ±0.3% (sensor-less vector control 1 & 2)
	Torque Response <10ms (sensor-less vector control 1&2)
Basic Functions	Starting Torque 0.5Hz: 180% (V/Fcontrol, sensor-less vector control 1) 0.25Hz:180 %(sensor-less vector control 2)
	Carrier Frequency 0.7kHz~16kHz
	Overload Capacity 150% Rated current 60s ; 180% Rated current 10s ; 200% Rated current 1s
	Torque Boost Automatic torque boost ; Manual torque boost 0.1%~30.0%
	V/F Curve Three ways: Straight ; Multi-point type ; N Th-type V/F curve
	Acceleration And Deceleration Curve Line or curve acceleration and deceleration mode Four kinds of acceleration and deceleration time, Ramp time range: 0.0~6000.0s
	DC Braking DC braking frequency: 0.00Hz~maximum frequency, braking time: 0.0s~10.0s, braking action current value: 0.0%~150.0%
	Jog Control Jog frequency range: 0.00Hz~50.00Hz, jog acceleration and deceleration time 0.0s~6000.0s.
	Simple PLC, Multi-Speed Operation Realize up to 16-stage speed operation through built-in PLC or control terminals
	Built-In PID It is convenient to realize the process control closed-loop control system
	Automatic Voltage Regulation (AVR) When the grid voltage changes, it can automatically keep the output voltage constant
	Command Source The control panel, control terminal, serial communication port given
Operate	Frequency Given 9 frequency sources: digital reference, keyboard potentiometer reference, analog voltage reference, analog current reference, pulse reference, serial port reference, multi-speed reference, PLG reference, and process PID reference. Can be switched in various ways
	Input Terminal 5 switch input terminals, one way to make high-speed pulse input 2-channel analog inputs, including 1-channel voltage input, 1-channel voltage and current options
	Output Terminal 1 switch output terminal, 1 relay output terminal, 1 analog output terminal
Special Feature	Parameter copy, parameter backup, flexible parameter displayed & hidden. Reliable speed search started. Timing control, fixed length control, count function, three faults recorded, overvoltage stall protection, undervoltage stall protection, restart upon power loss, Motor thermal protection, Wobble frequency control, High-precision torque
Protection	Provide fault protection function: overcurrent, overvoltage, undervoltage, overtemperature, overload protection etc .
Environment	Place Of Operation Indoors, no direct sunlight, free from dust, corrosive gases, flammable gases, oil mist, water vapor, water drop and salt, etc.
	Altitude 0~2000m De-rate 1 % for every 100m when the altitude is above 1000 meters
	Ambient Temperature -10℃~50℃
Other	Installation Wall-mounted or Flange mounting
	IP Grade IP20
	Cooling Method Fan cooled



Three Phase
380V : 0.75~630KW

Applications

FR500 series vector control inverter is for OEM customers of the mid-high market and for applications such as fan and pump , flexible design, embedded SVC and VF control, widely used in the applications with higher requirements, such as the speed control accuracy and torque response speed, low frequency output characteristics.

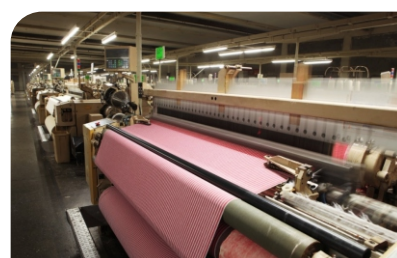

Excellent Performance

- High-start torque characteristic
- 0.5Hz can provide 180% start torque (Sensor-lessvector control 1)
- 0.25Hz can provide 180% start torque (Sensor-lessvector control 2)
- Sensorless vector control can reduce susceptibility of motor parameter, improve the field adaptability

Strong overload ability

- Heavy load overload capacity:
 - 110% rated stable operation
 - 150% rated load for 1min
 - 180% rated load for 10s
 - 200% rated load for 1s

Wide range voltage input with international standards

- Rated voltage: 3 phase 380-480V , 50Hz/60Hz
- Voltage fluctuation range:325-528V , 50Hz/60Hz

Perfect brake circuit scheme

- 45kW(G)-75kW(G) optional built-in braking unit
- Strong braking ability : The short-time braking ability can reach 1.1-1.4 times of inverter's rated power
- Brake protection is more comprehensive and intelligent

Speed tracking function

- In the case of fast start, the inverter can make the motor to start smoothly according to the current operation direction and speed of the motor

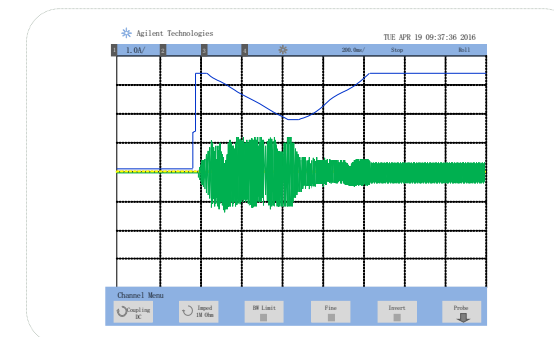

Speed tracking output frequency and current waveform

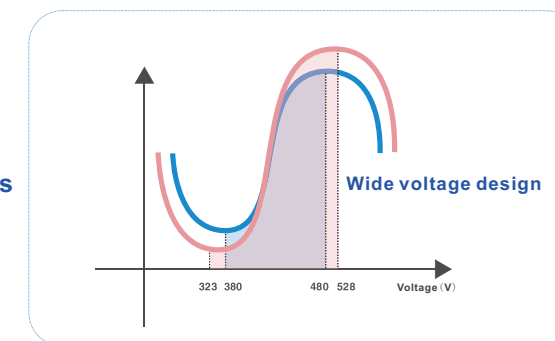

Wide voltage design

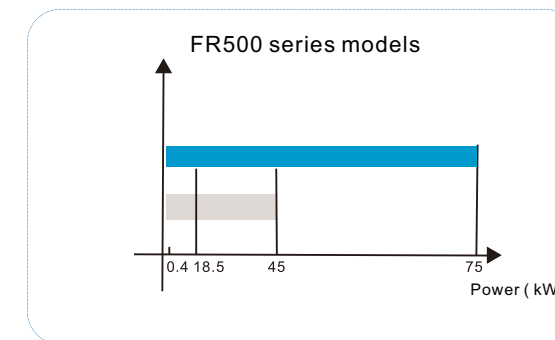

FR500A series: Below 37 kw (including 37 kw) , built-in brake unit.45 kw ~75 kw built-in brake unit is optional

New technology platform, large surplus derating design

- Adopt Infineon new generation of IGBT hardware platform, with higher configuration and large surplus derating design

Independent air duct

- The independent air duct design , can effectively prevent the dust from entering the inverter and causing the fault of short circuit, improve the reliability
- Select the long-life and max air flow rate cooling fans, effectively reduce inverter temperature rise, ensure reliable and stable operation

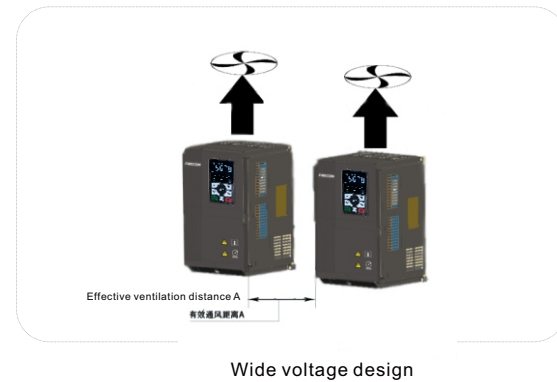

Optimized structural design, leading technology platform

- Compare with previous generation products of the same power , the size of FR500A series is smaller, greatly saves the installation space, it's convenient to layout the electronic control device ; maximum installation area reduced by 50%, volume reduced by 60%.
- Adopt a new generation of IGBT module technology, high junction temperature, high power density

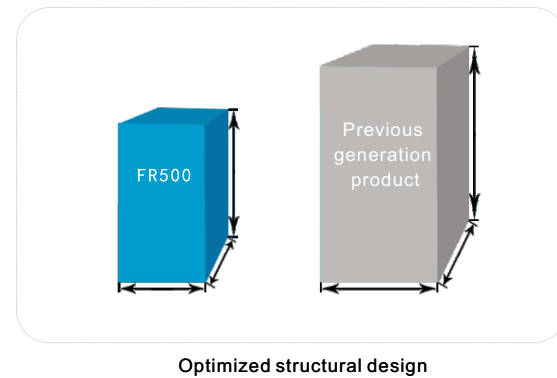

Convenient debugging

- Strong back background software
- Factory shortcut mode
It can quickly set the commonly used parameter options, allowing customers to save a lot of time to read the manual
- Dedicated upload and download module to facilitate parameter debugging
- Restore factory parameters, backup user parameters
- Develop special application macros according to industry needs

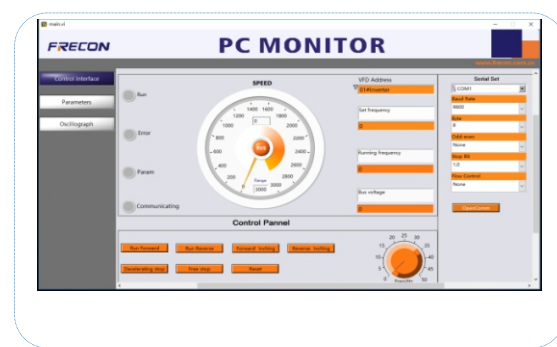

Nameplate And Electric Specification

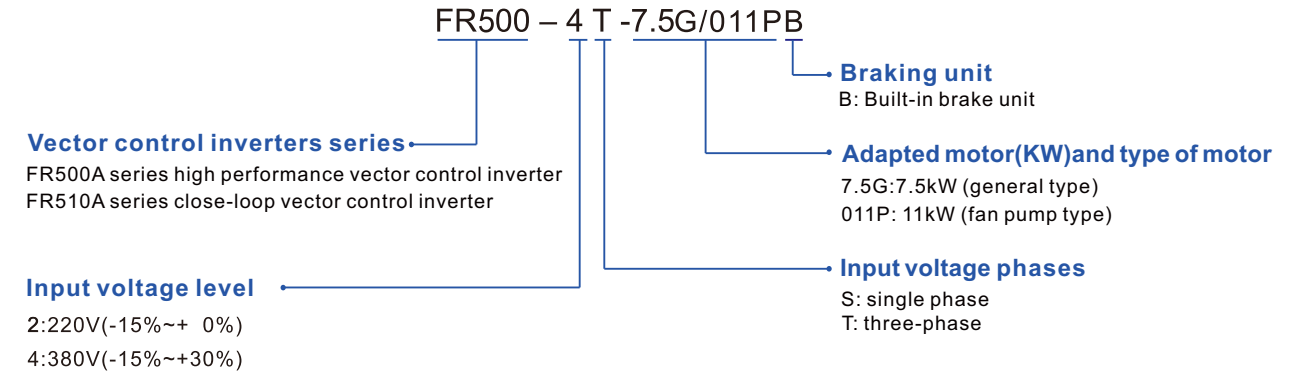

Model No.	Power Capacity (KVA)	Rated Input Current (A)	Rated Output Current (A)	Adapted Motor	
				kW	HP
Three-phase power supply: 380V, 50/60Hz Range: -15%~+30%					
FR500-4T-0.7G/1.5PB-H	1.5	3.4	2.5	0.75	1
FR500-4T-1.5G/2.2PB-H	3	5.0	4.2	1.5	2
FR500-4T-2.2G/4.0PB-H	4	5.8	5.5	2.2	3
FR500A-4T-4.0G/5.5PB-H	6	11	9.5	3.7/4	5
FR500A-4T-5.5G/7.5PB-H	8.9	14.6	13	5.5	7.5
FR500A-4T-7.5G/011PB-H	11	20.5	17	7.5	10
FR500A-4T-011G/015PB-H	17	26	25	11	15
FR500A-4T-015G/018PB-H	21	35	32	15	20
FR500A-4T-018G/022PB-H	24	38.5	37	18.5	25
FR500A-4T-022G/030PB-H	30	46.5	45	22	30
FR500A-4T-030G/037PB-H	40	62	60	30	40
FR500A-4T-037G/045P(B)-H	57	76	75	37	50
FR500A-4T-045G/055P(B)-H	69	92	91	45	60
FR500A-4T-055G/075P(B)-H	85	113	112	55	70
FR500A-4T-075G/090P(B)-H	114	157	150	75	100
FR500A-4T-090G/110P-H	134	186	176	90	125
FR500A-4T-110G/132P-H	160	220	210	110	150
FR500A-4T-132G/160P-H	192	260	253	132	175
FR500A-4T-160G/185P-H	231	310	304	160	210
FR500A-4T-185G/200P-H	240	355	350	185	250
FR500A-4T-200G/220P-H	250	382	377	200	260
FR500A-4T-220G/250P-H	280	430	426	220	300
FR500A-4T-250G/280P-H	355	475	470	250	330
FR500A-4T-280G/315P-H	396	535	520	280	370
FR500A-4T-315G/355P-H	445	610	600	315	420
FR500A-4T-355G/400P-H	500	665	650	355	470

Remarks: 1. (B) Built-in brake unit is optional;

Model No.	Power Capacity (KVA)	Rated Input Current (A)	Rated Output Current (A)	Adapted Motor	
				kW	HP
Three-phase power supply: 380V, 50/60Hz Range: -15%~+30%					
FR500-4T-400G/450P-H	565	690	725	400	530
FR500-4T-450G/500P-H	623	765	800	450	600
FR500-4T-500G/560P-H	670	835	860	500	660
FR500-4T-560G/630P-H	770	960	990	560	750

Technical Parameters

Item		Specification
Power Input	Rated Input Voltage (V)	Three-phase 380 V (-15%~ +30%)
	Rated Input Frequency (Hz)	50Hz/60 Hz, ± 5 %
Power Output	Maximum Output Voltage (V)	0V~U _{im} , error<±3%
	Maximum Output Frequency (Hz)	0.00~600.00 Hz, unit 0.01Hz
Control Characteristics	Control Mode	V/f control, vector control without PG 1, vector control without PG 2, vector control with PG
	Speed Range	1:50 (V/f control) , 1:100 (Vector control without PG 1) 1:200 (Vector control without PG 2)
	Speed Control Precision	±0.5% (V/f control), ±0.2% (without PG vector control 1, 2)
	Speed Fluctuation	±0.3% (without PG vector control 1, 2),
	Torque Response	<10ms (sensor-less vector control 2)
Basic Skills	Starting Torque	0.5Hz: 150% (V/f control without PG vector control 1), 0.25Hz: 150% (without PG vector control 2)
	Carrier Frequency	0.7kHz ~ 16kHz
	Overload Capacity	150% rated current for 60s, 180% rated current for 10s, 200% rated current for 1s.
	Torque Boost	Automatic torque boost; manual torque boost 0. 1%~30. 0%
	V/F Curve	Three ways: linear type; multi-point type; Nth power type V/F curve
	Acceleration And Deceleration Curve	Linear or S-curve acceleration and deceleration mode. Four kinds of acceleration and deceleration time, the acceleration and deceleration time range is 0. 0~ 6000.0s
Special Feature	DC Brake	DC braking frequency: 0. 00Hz~maximum frequency, braking time: 0. 0s~10. 0s, braking action current value: 0. 0%~150. 0%
	Protection	Parameters copy, parameters backup, flexible function code shown and hidden, reliable speed search, timing control, fixed-length control function and counting function, 14 group of fault records, overvoltage stall, under voltage stall, power-on restart, restarting function, the motor temperature protection function, frequency control operation , high accuracy of torque limiting, Sensor-less torque control
Environment	Operation Place	Indoors, no direct sunlight, no dust, no corrosive gases, no flammable gases, no oil mist, no water vapor, no water drop and salt, etc
	Altitude	0~2000m Derate 1 % for every 1 00m when the altitude is above 1000 meters
	Ambient Temperature	-10~40°C(when environment temperature is in 40~ 50°C, please derating use.)
Other	Installation	Wall-mounted or flange mounting
	IP Ddegree	IP20
	Cooling Method	Forced air cooling



Applications

FR510 series vector control inverter is mainly positioned for OEM customers in the mid-to-high-end market and applications for synchronous motors. Its design is flexible, embedded with SVC, VF, and VC controls, and can be widely used in speed control accuracy, torque response speed, Low frequency output characteristics have higher requirements The required application



General Purpose Inverter

General Purpose Inverter

New technology platform, large surplus derating design

- Adopt Infineon's new generation IGBT hardware platform, with higher configuration and large surplus derating design.

Oscillation suppression function

- When detected motor oscillation, automatic trimming output voltage and frequency make motor running smoothly

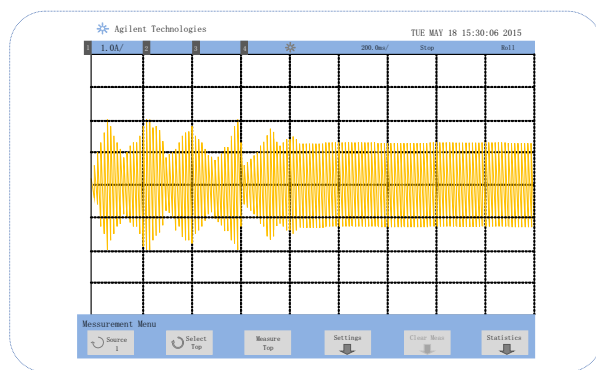

Oscillation Suppression Waveform

Built-in self-adaptive PID function module

- Built-in two groups of PID parameters, which can automatically switch according to the deviation, DIterminal and frequency conditions
- Given and feedback source selection is various, practical
- Detect function of PID feedback loss, which is convenient for user to detect faults
- support dormancy and wake up function, can be switched according to the frequency and pressure

Speed tracking function

- In the case of fast start, the inverter can make the motor to start smoothly according to the current operation direction and speed of the motor

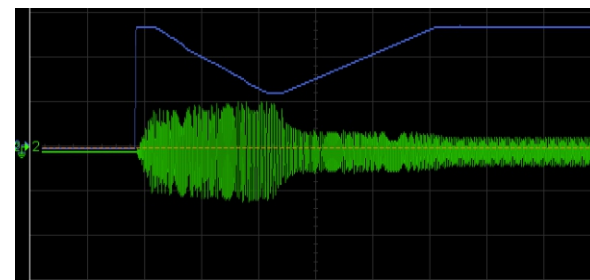

Speed tracking output frequency and current waveform

Strong overload ability

- Heavy load overload capacity:
150% rated load for 1min,
180% rated load for 10s,
200% rated load for 1s.

Flexible and diverse terminal functions

- Multi-function terminals DI, DO, AO have a variety of logic function options;
- The AI terminal can be flexibly selected as a multi-functional DI terminal;
- Built-in multiple sets of virtual DI and DO function selection, reducing external DI/DO wiring;
- Support high-speed pulse input and output, up to 100KHz

Match with various encoder (FR510A)

- Support 0C, push-pull, differential, EN1313, UVW resolver and other encoders

Comprehensive Protection Functions

- FR500A and FR510A series have comprehensive protection functions such as output to ground short circuit protection, fan drive circuit protection, external 24VDC short circuit protection, motor overload protection, optional Pt100 / PT1000 motor temperature protection function, etc.
- According to the severity of the fault type, it can be selected as pre-warning, fault stop and continuous operation, it is convenient for maintenance
- It can automatically pass voltage compensation under heavy load to achieve constant output voltage and meet the needs of the power supply industry.

Multiple Communication Expansion Card

- Support PROFIBUS, CAN, GPRS DTU and other communications
- Support a variety of PG cards and expansion cards

Model And Electric Specification

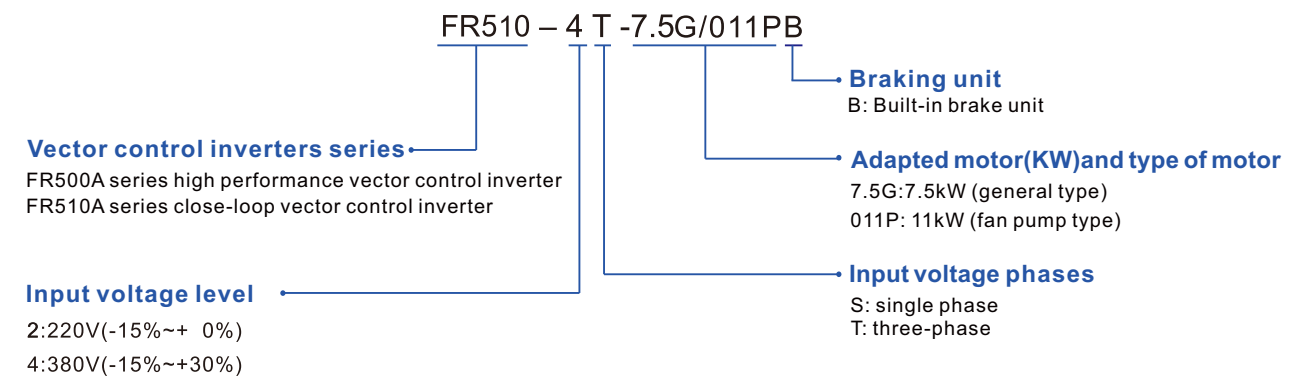

Model No.	Power Capacity (KVA)	Rated Input Current (A)	Rated Output Current (A)	Adapted Motor	
				kW	HP
Three-phase power supply: 380V, 50/60Hz Range: -15%~+30%					
FR510-4T-0.7G/1.5PB-H	1.5	3.4	2.5	0.75	1
FR510-4T-1.5G/2.2PB-H	3	5.0	4.2	1.5	2
FR510-4T-2.2G/4.0PB-H	4	5.8	5.5	2.2	3
FR510A-4T-4.0G/5.5PB-H	6	11	9.5	3.7/4	5
FR510A-4T-5.5G/7.5PB-H	8.9	14.6	13	5.5	7.5
FR510A-4T-7.5G/011PB-H	11	20.5	17	7.5	10
FR510A-4T-011G/015PB-H	17	26	25	11	15
FR510A-4T-015G/018PB-H	21	35	32	15	20
FR510A-4T-018G/022PB-H	24	38.5	37	18.5	25
FR510A-4T-022G/030PB-H	30	46.5	45	22	30
FR510A-4T-030G/037PB-H	40	62	60	30	40
FR510A-4T-037G/045P(B)-H	57	76	75	37	50
FR510A-4T-045G/055P(B)-H	69	92	91	45	60
FR510A-4T-055G/075P(B)-H	85	113	112	55	70
FR510A-4T-075G/090P(B)-H	114	157	150	75	100
FR510A-4T-090G/110P-H	134	186	176	90	125
FR510A-4T-110G/132P-H	160	220	210	110	150
FR510A-4T-132G/160P-H	192	260	253	132	175
FR510A-4T-160G/185P-H	231	310	304	160	210
FR510A-4T-185G/200P-H	240	355	350	185	250
FR510A-4T-200G/220P-H	250	382	377	200	260
FR510A-4T-220G/250P-H	280	430	426	220	300
FR510A-4T-250G/280P-H	355	475	470	250	330
FR510A-4T-280G/315P-H	396	535	520	280	370
FR510A-4T-315G/355P-H	445	610	600	315	420
FR510A-4T-355G/400P-H	500	665	650	355	470
FR510A-4T-400G/450P-H	565	785	725	400	530
FR510A-4T-450G/500P-H	623	865	800	450	600
FR510A-4T-500G/560P-H	670	835	860	500	660
FR510A-4T-560G/630P-H	770	960	990	560	750



FR30 Series High Performance Inverter



**Three Phase
380V : 0.75~110KW**

Applications

FR30 series is a new generation inverter of FRECON , with high performance, high quality and high power density design. It is mainly positioned as a full-featured product in the mid -to-high-end market. Its design is flexible, has built-in VC, SVC, and VF controls. Can be widely used in applications with high requirements for speed control accuracy, torque response speed ,and low-frequency output characteristics.



Excellent performance

- High starting torque characteristics:
- 0.5Hz can provide 150% start torque (Sensor-less vector control 1)
- 0.25Hz can provide 150% start torque (Sensor-less vector control 2)
- Sensor less vector control is less sensitive to motor parameters, improve the field adaptability

Flexible and diverse terminal functions

- Multi-function terminal DI, DO, AO has a variety of logic function
- AI terminal can be used as multi-function DI terminal, flexible to select
- Built-in multi-group virtual DI and DO function selection to reduce external DI/DO wiring
- Support high-speed pulse input and output, up to 100KHz

Reactors and EMC

- Harmonic reduction with dual DC reactors(Figure 1)
- Meet EN61000-3-12 harmonic standard
- With EMC C2 filters can be installed in the complex environment(Figure 2)



Figure 1

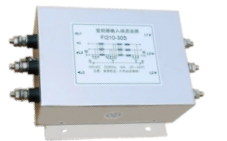

Figure 2

Reliability design

- Corrosion resistant coated circuit boards, minimizing airflow through control panel areas, design features such as ground failure protection, and a 50° C ambient design make the FR30 a safer selection

Operate when the V/F is fully separated and semi-detached

- an automatically compensate by voltage when overload, realize output voltage constant and meet the application requirements of power supply industry

Speed tracking function

- In the case of fast start, the inverter can realize the motor smooth and no impact start according to the current operation direction and rotate speed of the motor

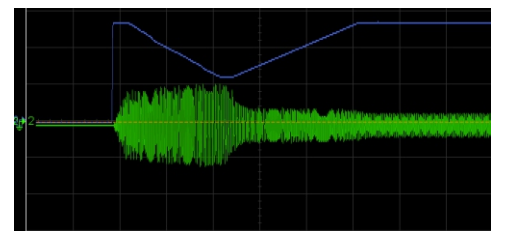

FR30 Model Description And Electric Spec

FR30-4 T-7.5 B

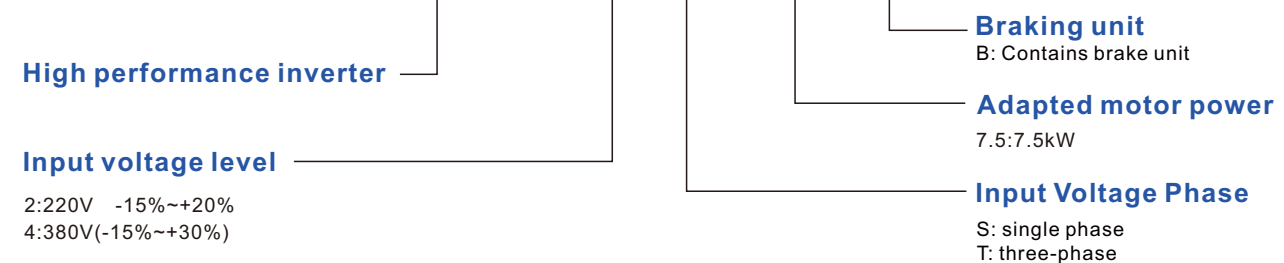

Model	Power Capacity (KVA)	Input Current (A)	Output Current (A)	Adapted Motor	
				kW	HP
FR30-4T-0.7B-H	1.5	3.4	2.5	0.75	1
FR30-4T-1.5B-H	3	5.0	4.2	1.5	2
FR30-4T-2.2B-H	4	5.8	5.5	2.2	3
FR30-4T-4.0B-H	6	11	9.5	4	5
FR30-4T-5.5B-H	8.9	14.6	13	5.5	7.5
FR30-4T-7.5B-H	11	20.5	17	7.5	10
FR30-4T-011B-H	17	26	25	11	15
FR30-4T-015B-H	21	35	32	15	20
FR30-4T-018B-H	24	38.5	37	18.5	25
FR30-4T-022B-H	30	46.5	45	22	30
FR30-4T-030B-H	40	62	60	30	40
FR30-4T-037(B)-H	57	76	75	37	50
FR30-4T-045(B)-H	69	92	91	45	60
FR30-4T-055(B)-H	85	113	112	55	70
FR30-4T-075(B)-H	114	157	150	75	100
FR30-4T-090(B)-H	134	186	176	90	125
FR30-4T-110(B)-H	160	220	210	110	150

Installation Dimensions

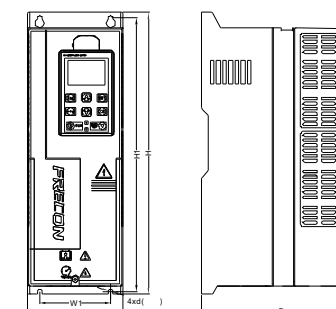

Model	External And Install Dimensions (mm)						Weight (Kg)
	W	W1	H	H1	D	Install Hole	
Three-phase power supply: 380V, 50/60Hz Range: -15% ~ +30%							
FR30-4T-0.7B-H	125	87	331	317	214	5.5	3.6
FR30-4T-1.5B-H							
FR30-4T-2.2B-H							
FR30-4T-4.0B-H							
FR30-4T-5.5B-H	125	87	385	371	214	5.5	4.5
FR30-4T-7.5B-H							
FR30-4T-011B-H	150	100	440	115	235	7	6.2
FR30-4T-015B-H							
FR30-4T-018B-H	195	150	485.4	470	232	7	9.5
FR30-4T-022B-H							
FR30-4T-030B-H							
FR30-4T-037(B)-H	210	150	588.4	570	258	7	12.1
FR30-4T-045(B)-H							
FR30-4T-055(B)-H	250	200	550	534	368.8	6.5	31.54
FR30-4T-075(B)-H							
FR30-4T-090(B)-H	265	/	601	/	370	/	/
FR30-4T-110(B)-H							

Technical Parameters

Item		Specification
Power Input	Rated Input Voltage (V)	3-Phase 380V -15%~+30%
	Rated Input Frequency (Hz)	50Hz/60Hz ±5%
Power Output	Rated Output Voltage(V)	0~Rated Input Voltage Error±3%
	Rated Output Frequency(Hz)	0.00~600.00Hz Unit:0.01Hz
Control Characteristics	Control Method	V/F Control Sensor-less vector control 1 Sensor-less vector control 2 Close-Loop Vector Control
	Speed Range	1:50 V/F Control 1:100 Sensor-less vector control 1 1:200 Sensor-less vector control 2 1 1000 Close-Loop Vector Control
	Speed Control Accuracy	±0.5% V/F Control ±0.2% Sensor-less vector control 1/2 ±0.1% Close-Loop Vector Control
	Speed Fluctuation	±0.3% Sensor-less vector control 1/2 ±0.1% Close-Loop Vector Control
	Torque Response	< 10ms(Sensor-less vector control)
	Starting Torque	0.5Hz:150%(V/F Control Sensor-less vector control 1) , 0.25Hz:180%(Sensor-less vector control 2), 0.00Hz:180%(Close-Loop Vector Control)
Basic Functions	Carrier Frequency	0.7kHz~16kHz
	Overload Capacity	150% rated current for 60s, 1 80% rated current for 10s, 200% rated current for 1s
	Torque Boost	Automatic torque boost; manual torque boost 0.1%~30.0%
	V/F Curve	Three ways: linear type: multi-point type; N-time equation V/F curve
	Acceleration/Deceleration Curve	Linear or S-curve acceleration and deceleration methods; four acceleration and deceleration times, the acceleration and deceleration time range is 0.0~6000.0s
	DC Braking	DC braking frequency: 0.00Hz~maximum frequency; braking time: 0.0s~ 10.0s; braking action current value: 0.0%~ 150.0%
Run	Command Source	Command Source Given the control panel, control terminal, serial communication port given.
	Frequency Ggiven	9 kinds of frequency sources
	Input Terminal	5 switch input terminals, one of which can be used as high-speed pulse input. Compatible with active open collector NPN, PNP and dry contact input methods.2 analog input terminals, 0~10V/0~20mA voltage and current optional
	Output Terminal	1 switch output terminal, supporting maximum 100kHz high-speed pulse output, 2 relay output terminals, 2 analog output terminals, and voltage and current are optional, which can realize the output of physical quantities such as set frequency and output frequency
Featured Functions	Parameter copy, parameter backup, flexible parameter displayed & hidden, common DC bus,Reliable speed search started, timing control, fixed length control, count function. 14 group faults recorded, overvoltage, under voltage, high-precision torque control, V/f separated control, torque control, sensor-less vector control and vector control.	
Protection	Provide fault protection dozen: Over-current, Over-voltage, Under-voltage, Over-temperature, Over-load Etc Protection.	
Display And Keyboard	LCD Display	Display parameters
	Key Lock And Function Selection	Realize the partial or complete locking of the keys, and define the scope of action of some keys to prevent misuse
	Parameter Backup	Can support backup of 3 sets of different setting parameters
Environment	Operation Plase	Indoors, free from direct sunlight, dust, corrosive gas, flammable gas, oil mist, water vapor, dripping water or salt, etc.
	Altitude	0~2000m De-rate 1% for every 100m when the altitude is above 1000 meters
	Ambient Temperature	-10°C~40°C(When environment temperature above 40°C, derating use)
Other	Installation	Wall-mounted or Flange mounting
	IP Grade	IP20/IP54
	Cooling Method	Forced air cooling



Applications

FR600 Series can be customized designed for industry solutions in Metallurgy, Crane, Petro, Chemical and Mining industries. Specifically France, Germany, Finland, South Africa and other countries developed industrial grid voltage for medium voltage drives.



General Purpose Inverter

General Purpose Inverter

Excellent performance

- High starting torque
- 180%Rated torque / 0.5Hz(SVC 1)
- 180% Rated torque / 0.25Hz(SVC 2)
- Reduce the sensitivity from SVC control to motor parameter,to improve the site adaptability



Superior Immunity design

- Wide operating voltage range, low voltage by over-modulation technology to ensure load capacity.
- On the grid surge (lightning strike), power grid noise, electrostatic immunity, to harsh industrial standards.
- Control power and bus separation; control power transformer isolated isolation separate power supply, control power standard design of the filter circuit.

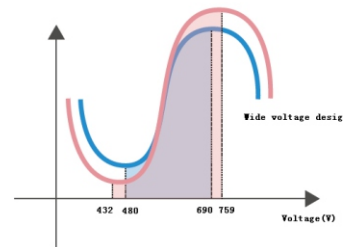

Superior environmental adaptability

- Standard products using three anti-paint treatment
- Duct isolation technology, resistant to moisture, dust, sealed design, easy to deal with harsh industrial environments.

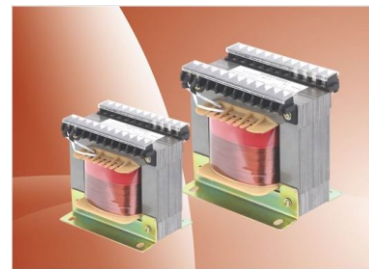

Large margin derating design

- 32 bit Cortex-M3 ARM core host CPU, clocked at144MHz.
- Infineon IGBTmodule 1700V voltage level.
- 100ov voltage electrolytic capacitors (50ov grade),
- 180ov voltage rectifier module (50ov grade),
- 120ov voltage electrolytic capacitors (66ov grade)
- 240ov voltage rectifier module (66ov grade)

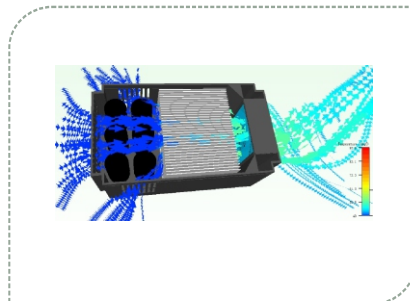

Convenient debugging

- Powerful background software
- Short-cut menu
Common parameters setting rapidly to save customer's time to read manual
- Design special application macro according to industry demand
- Unique upload and download module which is convenient for parameter commissioning. Restore factory parameters, backup user parameters

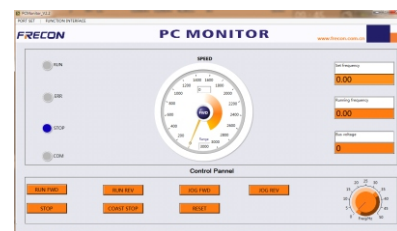

Model Description And Electric Spec

FR600 – 6 T - 075

Adapted motor power

075:75kW

Input Voltage Phase

T: three-phase

Input voltage level

5:550V

6:690V

Medium voltage inverter series

Mains Voltage	Model	Adapted Motor (kW)	Power Capacity (KVA)	Input Current (A)	Output Current (A)	Size Of The Case	Dimension (W*H*D) (mm)
Three-Phase 550VAC	FR600-5T-4.0-H	4	7.5	8	7.6	F6-1	198*300*185
	FR600-5T-5.5-H	5.5	12	12	11		
	FR600-5T-7.5-H	7.5	15	16	14.5		
	FR600-5T-011-H	11	20	21	20		
	FR600-5T-015-H	15	28	30	28		
	FR600-5T-018-H	18.5	35	37	35		
	FR600-5T-022-H	22	40	42	40	F6-2	270*130*270
	FR600-5T-030-H	30	52	55	52		
	FR600-5T-037-H	37	64	68	64		
	FR600-5T-045-H	45	77	82	77		
	FR600-5T-055-H	55	97	103	98	F6-3	430*825*305
	FR600-5T-075-H	75	125	130	124		
	FR600-5T-090-H	90	148	157	150		
	FR600-5T-110-H	110	178	189	180		
	FR600-5T-132-H	132	217	231	220		
	FR600-5T-160-H	160	257	273	260	F6-4	660*1030*359
	FR600-5T-185-H	185	297	315	300		
	FR600-5T-200-H	200	326	346	330		
	FR600-5T-220-H	220	356	378	360		
	FR600-5T-250-H	250	410	435	414		
FR600-5T-280-H	280	452	480	458			
FR600-5T-315-H	315	505	535	510	F6-5	810*1167*460	
FR600-5T-355-H	355	565	600	573			
FR600-5T-400-H	400	632	670	646			

General Purpose Inverter

General Purpose Inverter

690VAC	FR600-6T-015-H	15	27	23	20	F6-1	198*300*185
	FR600-6T-018-H	18.5	35	30	25		
	FR600-6T-022-H	22	37	35	28		
	FR600-6T-030-H	30	43	40	35		
	FR600-6T-037-H	37	51	47	45	F6-2	270*130*270
	FR600-6T-045-H	45	65	52	52		
	FR600-6T-055-H	55	80	67	65		
	FR600-6T-075-H	75	93	82	86		
	FR600-6T-090-H	90	123	96	98		
	FR600-6T-110-H	110	147	120	124	F6-3	355*620*290
	FR600-6T-132-H	132	166	145	150		
	FR600-6T-160-H	160	229	175	180		
	FR600-6T-185-H	185	236	190	200		
	FR600-6T-200-H	200	258	210	220		
	FR600-6T-220-H	220	286	235	245		
	FR600-6T-250-H	250	316	255	270	F6-4	430*825*305
	FR600-6T-280-H	280	346	290	300		
	FR600-6T-315-H	315	367	335	350		
	FR600-6T-355-H	355	454	370	390		
	FR600-6T-400-H	400	488	415	430		
FR600-6T-450-H	450	559	460	480			
FR600-6T-500-H	500	645	520	540			
FR600-6T-560-H	560	660	580	600	F6-5	660*1030*359	
FR600-6T-630-H	630	812	655	680			
FR600-6T-710-H	710	910	750	770			
FR600-6T-710-H	710	910	750	770			



FR580 Series
IP65 Inverter



Single Phase
220V : 0.4~3KW
Three Phase
380V : 2.2~55KW

General Purpose Inverter

General Purpose Inverter

Technical Parameters

Main Power	Input Voltage Uin	Three-phase 690vAC (- 30%, + 10%) Three-phase 550VAC (- 30%, + 10%)
	Input Frequency	50/60Hz
Motor Connection	Output Voltage	0VAC ~ Uin
	Output Frequency	0Hz~600Hz
	Frequency Resolution	0.01Hz
	Overload Capacity	150% for 1 min, 180% for 10 s, 200% for 2 s
Control Characteristics	Control Mode	VF control, vector control without PG 1, vector control without PG 2, vector control with PG
	Carrier Frequency	0.7kHz ~ 16kHz
	Acceleration Time	0.1s ~6000.0s
	Deceleration Time	0.1s ~6000.0s
	Torque Boost	Automatic torque boost, manual torque boost 0.1 ~ 30.0%
	DC Braking	DC braking frequency: 0~maximum frequency; braking time: 0.0~10.0s; braking action current value: 0.0~150.0%

Applications

FR580 series is a high-protection inverter with complete over-current, over-voltage, overload, under-voltage, under-load and other protection functions. It is widely used in outdoor and strong corrosive gas environments.



Feature

- IP65 design, high protection level outdoor installation model
- Adopt natural cooling method, low noise (7.5KW and below power)
- Widely used in various AC asynchronous motors, synchronous motors, reluctance motors
- GPRS remote monitoring real-time running status, real-time start and stop (optional)
- Operating environment temperature range: -25~60 degrees
- It has perfect overcurrent, overvoltage, output phase loss protection, short circuit, overheating and other protection functions

Terminal Diagram

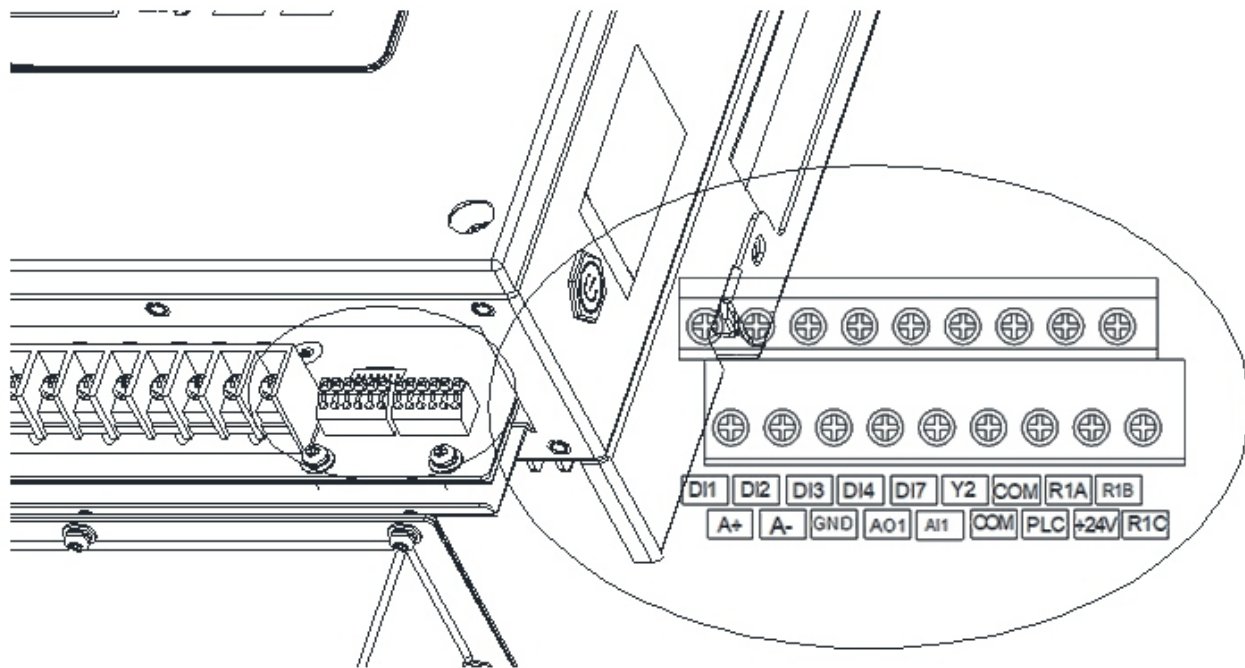

Inverter Size

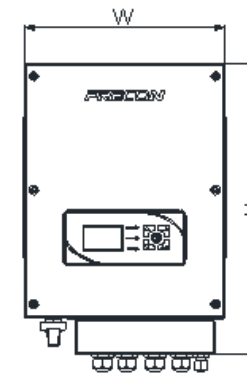

Figure 1-4 Schematic diagram of product size (≤22KW)

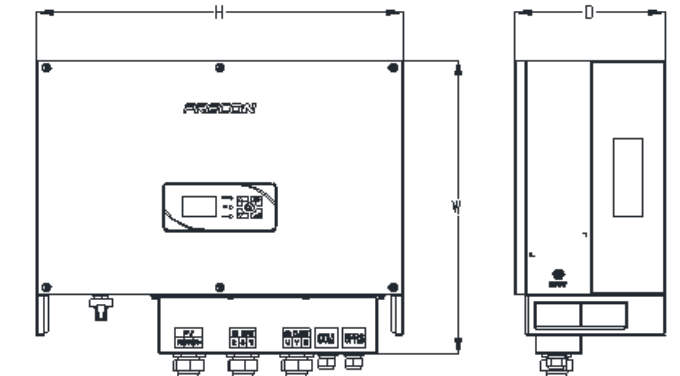

Figure 1-5 Schematic diagram of product size (≥30kW)

Model	External And Installation Dimensions (mm)			N.W (Kg)
	W	H	D	
FR580-2S-0.4-H	280	440	150	11.4
FR580-2S-0.7-H				
FR580-2S-1.5-H				
FR580-2S-2.2-H				
FR580-2S-3.0-H				
FR580-4T-2.2-H				
FR580-4T-4.0-H				
FR580-4T-5.5-H	340	538	186	17.5
FR580-4T-7.5-H				
FR580-4T-011-H				
FR580-4T-015-H				
FR580-4T-018-H				
FR580-4T-022-H	500	550	225	35
FR580-4T-030-H				
FR580-4T-037-H				
FR580-4T-045-H				
FR580-4T-055-H				

General Purpose Inverter

General Purpose Inverter

Technical Parameters

Model	Power Capacity (KVA)	Input Current (A)	Output Current (A)	Adapted Motor	
				kW	HP
Single-phase power supply: 220V, 50/60HZ Range: -15%~ +20%					
FR580-2S-0.4-H	1.0	6.5	2.5	0.37	0.5
FR580-2S-0.7-H	1.5	9.3	4.2	0.75	1.0
FR580-2S-1.1-H	1.1	11	5.5	1.1	1.5
FR580-2S-1.5-H	3.0	15.7	7.5	1.5	2
FR580-2S-2.2-H	4.0	24	9.5	2.2	3
FR580-2S-3.0-H	6.0	30	17	4.0	5
Three-phase power supply: 380V, 50/60HZ Range: -15%~ +30%					
FR580-4T-2.2-H	4.0	5.8	5.5	2.2	3
FR580-4T-4.0-H	6.0	11	9.5	4	5
FR580-4T-5.5-H	8.9	14.6	13	5.5	7.5
FR580-4T-7.5-H	11	20.5	17	7.5	10
FR580-4T-011-H	17	26	25	11	15
FR580-4T-015-H	21	35	32	15	20
FR580-4T-018-H	24	38.5	37	18.5	25
FR580-4T-022-H	30	46.5	45	22	30
FR580-4T-030-H	40	62	60	30	40
FR580-4T-037-H	57	76	75	37	50
FR580-4T-045-H	69	92	91	45	60
FR580-4T-055-H	85	113	112	55	70

Special Purpose inverter



- SY380 Series Voltage Boost Inverter
- FR500H Series Multi-Pump Constant Pressure Inverter
- FR500D Series Special Purpose Inverter For Elevator
- FR500S Series High Frequency Special Purpose Inverter
- FR500L Series Wire Drawing Machine Special Purpose Inverter
- FR500KFJ Series Open-Frame Special Purpose Inverter
- IF500 Series IP65 Industrial Fan Inverter

General Purpose Inverter

Special Purpose Inverter

SY380 Series Voltage Boost Inverter



Three Phase 380V : 0.75~400KW



- Support dandy -removing function and clear the blockage of water pumps.
- Multiple protection, let customers use with confidence; The protection function is complete, there are multiple protection, overload, overwhelming, overcurrent and other protection.
- Function and general inverter -rich; Built -in PID, simple PLC, multi -speed function. Various V/F control curves can meet different application requirements.
- Compared with the transformer scheme, the size is smaller and the cost is lower;
- Derating design of components and high reliability
- Excellent performance: High start torque, Strong overload capacity

Applications

SY380 series inverter is a special inverter designed for the civil power grid (single-phase 220VAC) driven 380VAC motor. No need to add the transformer, then customer can easily drive 380V AC motor with this series.



FR500H Series Multi-Pump Constant Pressure Inverter



Three Phase 380V : 0.75~400KW



Ideal for multi-pumps constant pressure water supply and sewage treatment of residential building and municipal projects, with the function of easy setting of power frequency pumps, variable frequency pumps, dormant pumps, and auto-switch according to system status, timing constant pressure water supply, dormancy control, self-cleaning control, timing rotation control, water level control, and pipeline pressure detection and protection.

- Support dandy -removing function and clear the blockage of water pumps.
- Support dry pumping detection function to prevent the pump from burning out.
- Support pressure sleep and wake up function.
- Support the pipepressure filling function to prevent pressure overshoot at startup (slowly run the pipe before starting PID adjustment for pressure filling).
- Multiple rotation modes (to prevent single water pumps from running for a long time).
- Multiple water pump control mode.
- Support 1 frequency trailer 4 industrial frequency motor

Applications

FR500H multi -pump constant voltage water supply -specific inverter is based on the core algorithm of the FR500 vector control inverter, combined with the application control requirements of constant pressure water supply, a special inverter developed, which has a living community and municipal engineering. Multi -pump constant pressure water supply and sewage treatment function



FR500D Series Special Purpose Inverter For Elevator

Three Phase 380V : 4.0~75KW



- Can drive AC three-phase asynchronous motor and AC permanent magnet synchronous motor
- Support opening and closed-loop control
- Unique S curve and inductive weight function
- Start, stop parking, good comfort, flat layer accurate
- Unique short floor function with shortest time to ensure the operation efficiency
- When UPS provides a power supply, run in the emergency operation mode
- Calligraphy of Elevator Logic Logic Control

Applications

FR500D series inverter is designed according to the carrying characteristics of elevator. It adopts high performance vector control technology, can control both asynchronous motor and synchronous motor. For asynchronous motor open-loop vector control, it combined with innovative sensor start/stop compensation technology without weighting to ensure the comfort when elevator start/stop without weighting device.



FR500S Series High Frequency Special Purpose Inverter

Three Phase 380V : 0.75~400KW



The FR500S series is a high-frequency closed-loop-specific inverter based on the FR510 platform, with high performance, high-quality, high-power density design. The main positioning is OEM customers with the mid-to-high-end market, with flexible design, embedded VC, SVC, VF control and one, supporting synchronous motor control, various PG cards, main axis orientation, pulse follow-up, zero servo and other position control. It can be widely used in applications that have high requirements for speed control accuracy, torque response speed, and low-frequency output characteristics.

- 0Hz ~ 4000Hz adjustable;
- The current is stable, the speed is not fluctuated, and the high frequency torque is large;
- Can achieve the motor fast stop, good current waveform, high accuracy;
- Perfect protection functions: input, output lack of phase protection, short circuit protection, overcurrent protection, overload protection, etc. Nearly 20 kinds of protection
- It has the advantages of fast speed, small volume, lightweight, low material consumption, low noise, low vibration and other advantages;

Applications

The FR500S series high-speed motor drive inverter developed independently developed by our company can reach the highest output frequency of 4000Hz, which can well meet the field processing fields, such as workers, computer carving machines, CNC carvings, precision grinding machines and other customers. need.

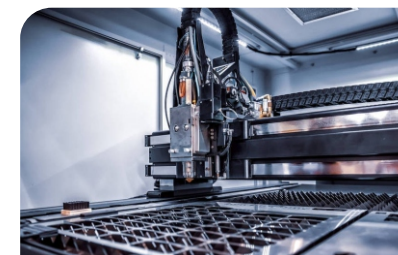

FR500L Series Wire Drawing Machine Special Purpose Inverter

Three Phase 380V : 0.75~132KW



- Rich dedicated machine macro application**
 Select the application macro according to mechanical equipment to reduce parameter adjustment
- Compact structure**
 Compared to the same industry, the size is small, saving the installation space
- User menu custom**
 Suitable for the machinery and equipment of wire and cable industry such as water tank -type drawing hosts, water tank -type drawing rollers, direct -to -incert
- Stand -up on any location**
 It can be turned on at any position of the lower limit, middle point or upper limit of the tension balance rod, and automatically track the speed of the drawing line.
- Plascrons are not moving**
 Automatically track the speed of drawing lines, and the tension balance rod is basically maintained at the position of the balance rod. Regardless of the empty disk, half -plate, full disk, regardless of the thick lines, fine lines, whether low, medium -speed, high -speed, tension is always constant

Applications

The FR500L series wire -pull machine industry special inverter is based on the FR500 inverter control algorithm, combined with the application control requirements of the drawing machine, and developed a special inverter specifically for the wire pull machine industry. It can be turned on at any position such as the lower limit of the tension balance rod, the middle point zero or upper limit.

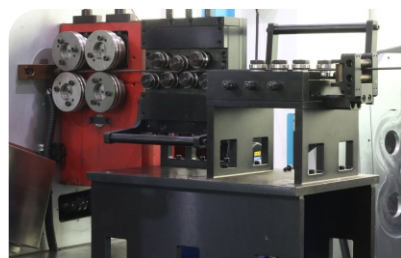

FR500KFJ Series Open-Frame Special Purpose Inverter

Three Phase 380V : 18.5~400KW



- User menu custom**
 Users can design the product appearance according to the actual situation of the site, which is consistent with the overall style of the equipment and not abrupt. It provides customers with customized services
- Provide OEM services to reduce costs for customers**
- Ultra-thin design, save 20%-50%thick space**
- The installation method of the middle partition is suitable for the safety isolation of the thermal source and the electrical system**
- Function, performance is the same as the FR200 series**
- Protection level IP00, users must cooperate with electrical control cabinet installation and use**

Applications

In accordance with market demand, Furuken launched the FR500KFJ open structure inverter, which consists of two parts: movement and radiator. Its functions and performance are the same as the FR500.

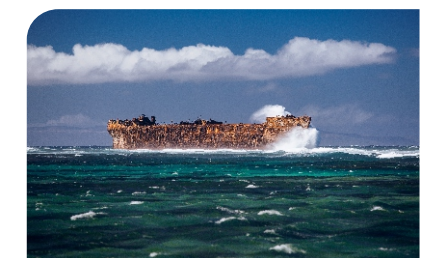
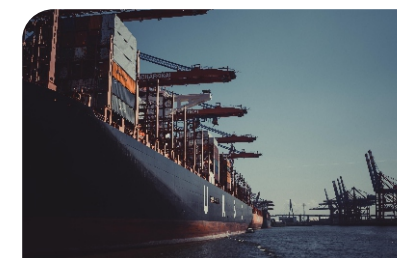

IF500 Series IP65 Industrial Fan Inverter

Single 220V : 1.5KW
Three Phase 380V : 1.5~2.2KW

- For the more extensive industrial fan application, we have developed an integrated industrial fan controller IF500 with small size, simple assembly, and beautiful shape.
- Good compatibility, can drive synchronization and asynchronous motor
- **Integration**
Digital display, digital knob speed adjustment, start-stop buttons. No need to assemble manually, just wiring
- **Convenient wiring, using waterproof terminals, top-in and top-out wiring**
- **Easy to use**
No need to connect control wires, just power on and operate the knobs and buttons.



Special Purpose Inverter

Applications

Industrial fan is a common industrial machine widely used in high and large spaces such as industrial plants, logistics storage, waiting rooms, exhibition halls, gymnasiums, supermarkets, etc., as a space ventilation and personnel cooling. Compared with traditional HVAC and small high-speed fans, it has unparalleled application advantages.



Servo Drive System





SD300 Series Servo Drives



Single Phase
220V : 0.1~0.4KW

Three Phase
220V : 1-1.5KW

Three Phase
380V : 3-5.5KW

Applications

SD300 series AC servo system is a new generation of motion control products of our company. It has the characteristics of excellent performance, good stability and easy to use. It can be widely used in CNC machine tools, electronic processing equipment, packaging machinery, printing machinery, textile machinery, industrial robots, automated production and other industries. Realize fast and accurate position control, speed control and torque control.

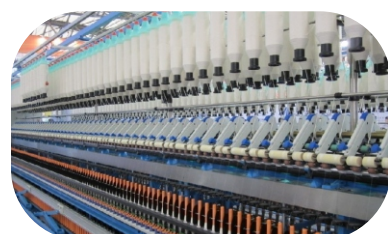

Feature

- **High precision encoder**
With 17bit, 23bit absolute value encoder, significantly improve the repeated positioning accuracy and absolute positioning accuracy of the equipment
- **High response bandwidth**
The response bandwidth can reach 3kHz, which greatly improves the servo performance
- **Inertia identification**
The load inertia ratio is an important parameter of the servo system. Correct setting of load inertia ratio helps to complete commissioning quickly
- **Friction compensation**
The friction compensation function reduces the influence of the friction force in the mechanical transmission on the operation effect, and performs different positive and negative compensation values according to the positive and negative directions of the operation
- **Switch freely through the three rings of external input signal**
Can switch between speed/position, speed/current, position/current
- **Support three kinds of pulse form input**
Pulse + direction, pulse + pulse, quadrature input
- **Vibration suppression function**
 - 1: Mechanical resonance suppression:
The mechanical system has a certain resonant frequency, when the servo gain increases, Resonance may occur near the mechanical resonance frequency, making it impossible to increase the gain further. Can be suppressed by torque command filtering and notch filter
 - 2: End low frequency suppression:
If the end of the mechanical load is long and heavy, it is easy to cause end vibration during emergency stop. This vibration can be effectively reduced by the low frequency resonance suppression function

SD300 Series Drive Model Description

Model Description

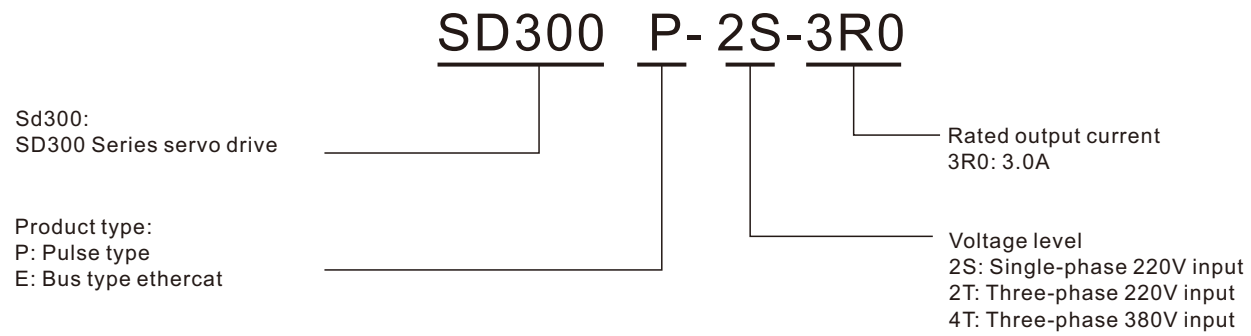

Product Dimensions

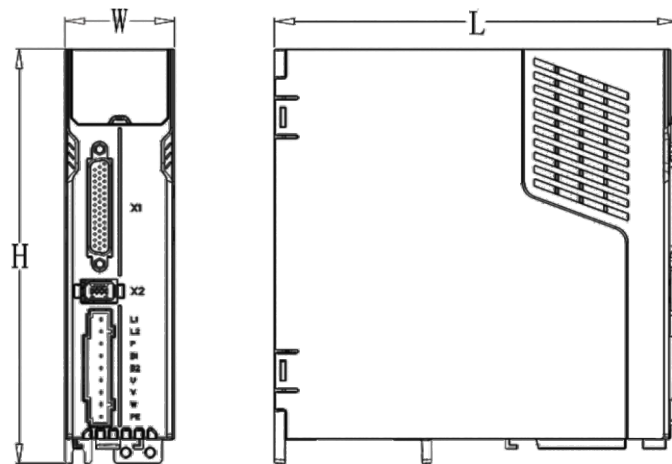

Model	Dimensions Table (mm)		
	W	H	L
SD300P-2S-3R0-H	45	170	166
SD300P-2S-5R5-H	45	170	166
SD300P-2T-7R6-H	66	171	172
SD300P-2T-012-H	79	171	172
SD300P-4T-012-H	79	171	172
SD300P-4T-017-H	95	230	250
SD300P-4T-021-H	95	230	250

Technical Parameters(Pulse Version)

Model(SD300P)	2S-3R0-H	2S-5R5-H	2T-7R6-H	2T-012-H	4T-012-H	4T-017-H	4T-021-H
Rated Output Current (A)	3.0	5.5	7.6	12.0	12.0	17.0	21.0
Maximum Output Current (A)	9	14	18	32	30	40	50
Input Power	Main Power	Single phase AC200V-240V, -10%~+10%50/60Hz		Three phase AC200V-240V, -10%~+10%, 50/60Hz		Three phase AC380V-440V, -10%~+10%, 50/60Hz	
	Control Power	Take power from the bus, share power input and rectification		Single phase AC200V-240V, -10%~+10%, 50/60Hz		Single phase AC380V-440V, -10%~+10%, 50/60Hz	
Environment	Temperature	Working/storage: 0°C to 55°C (the ambient temperature is above 45°C, derate by 10% for every 5°C increase) / -20°C to 70°C					
	Humidity	Work/storage: below 90%RH (no condensation)					
	Atmospheric Pressure	86kPa ~ 106kPa					
Degree Of Protection	IP20						
Regenerative Braking	Built-in/external				Built-in/external	External	
Feedback	Single-turn/multi-turn absolute encoder (Tamagawa protocol)						
Control Mode	Position, speed, torque						
Digital Input	7 programmable input terminals (photoelectric isolation) functions: servo enable, alarm clear, forward drive prohibition, reverse drive prohibition, forward torque limit, reverse torque limit, emergency stop, electronic gear selection 1, electronic Gear selection 2, position deviation clear, pulse input prohibition, etc.						
Digital Output	5 programmable output terminals (photoelectric isolation) functions: servo ready, alarm, positioning complete, speed arrival, electromagnetic brake, torque limit, etc.						
Encoder Signal Output	5 programmable output terminals (photoelectric isolation) functions: servo ready, alarm, positioning complete, speed arrival, electromagnetic brake, torque limit, etc.						
Location	Input Frequency	Differential input: ≤1000kHz(kpps) Single-ended input: ≤200kHz(kpps)					
	Command Mode	Pulse+sign, forward/reverse pulse, quadrature pulse					
	Electronic Gear Ratio	1 ~ 32767/1 ~ 32767					
Speed	Analog Command Input	-10V~+10V, input impedance 10kΩ					
	Command Acceleration Deceleration	Parameter settings					
	Command Source	Analog quantity, pulse frequency					
Torque	Analog Command Input	-10V~+10V, input impedance 10kΩ					
	Speed Limit	Parameter settings					
	Command Source	Analog					
Monitoring Function	Speed, current position, position deviation, motor torque, motor current, command pulse frequency, bus voltage, module internal temperature, etc.						
Protective Function	Overspeed, overvoltage, overcurrent, overload, brake abnormality, encoder abnormality, position tolerance, etc.						
Communication	Modbus RTU						
Host Computer Interface	USB, support parameter reading and writing, waveform recording, online upgrade						

Servo Drive System

Servo Drive System

Servo Motor Model Description

F 1 M - 4 0 1 3 0 2 2 2 0 0 0 - A 3 6 0

① ② ③ ④ ⑤ ⑥ ⑦ ⑧

①	Symbol	Name
	F1	The first generation of servo motors
②	Symbol	Rotor Inertia
	M	H: High inertia M: medium inertia S: Low inertia
③	Symbol	Rated Power (W)
	401	40 X 10 ¹ = 400
④	Symbol	Rated Speed (rpm)
	302	30 X 10 ² =3000
⑤	Symbol	AC Input Voltage
	220	220:220V 380:380V

⑥	Symbol	Brake, Oil Seal
	00	00: No brake, no oil seal 01: No brake, with oil seal 10: With brake, no oil seal 11: With brake, with oil seal
⑦	Symbol	Encoder Type
	A3	A1: 17-bit absolute value single-turn A2: 17-bit absolute value multi-turn A3: 23-bit absolute value single-turn A4: 23-bit absolute value multi-turn
⑧	Symbol	Motor Flange
	60	40:40 flange 60:60 flange 80:80 flange 13:130 flange

Adaptation Table

Power	Servo Drive Model	Servo Motor Model	Servo Motor Specifications
0.4KW	SD300P-2S-3R0	F1M-40130222011-A360	1.27Nm,3000rpm,0.4KW,220V
0.75KW	SD300P-2S-5R5	F1M-75130222001-A380	2.39Nm,3000rpm,0.75KW,220V
0.75KW	SD300P-2S-5R5	F1M-75130222011-A380	2.39Nm,3000rpm,0.75KW,220V
1KW	SD300P-2T-7R6	F1M-10215222001-A313	6.37Nm,1500rpm,1KW,220V
1.5KW	SD300P-2T-012	F1M-18215222001-A313	11.46Nm,1500rpm,1.8KW,220V
3KW	SD300P-4T-012	F1M-30215238001-A318	19.1Nm,1500rpm,3KW,380V
5KW	SD300P-4T-017	F1M-45215238001-A318	28.65Nm,1500rpm,4.5KW,380V
6KW	SD300P-4T-021	F1M-55215238001-A318	35Nm,1500rpm,5.5KW,380V

Motor Dimensions

60 Motor dimensions

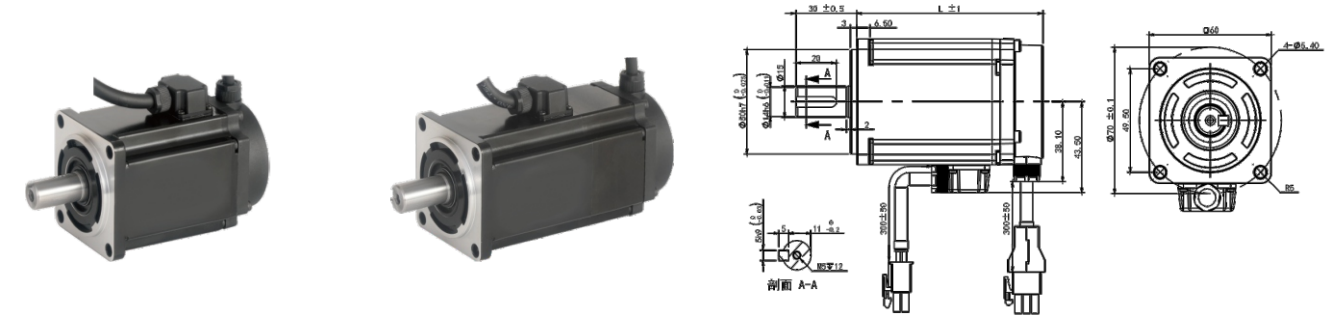

80 Motor dimensions

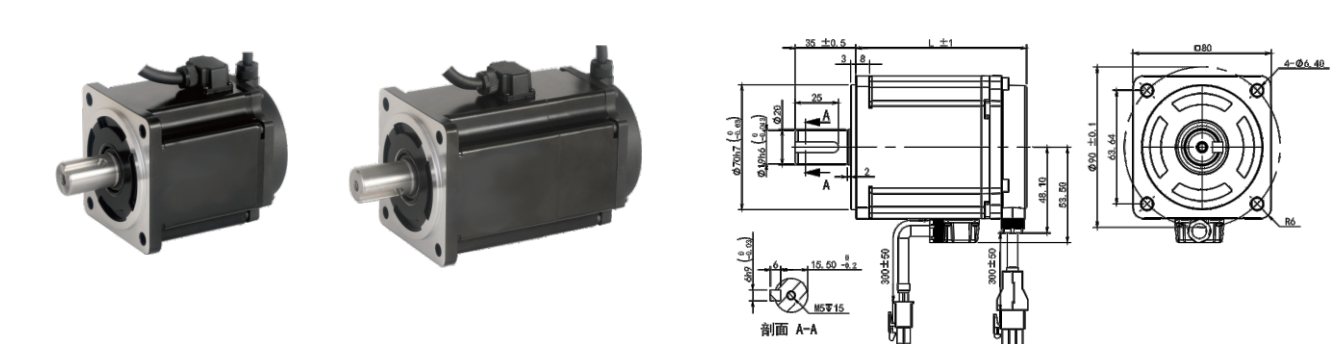

130 Motor dimensions

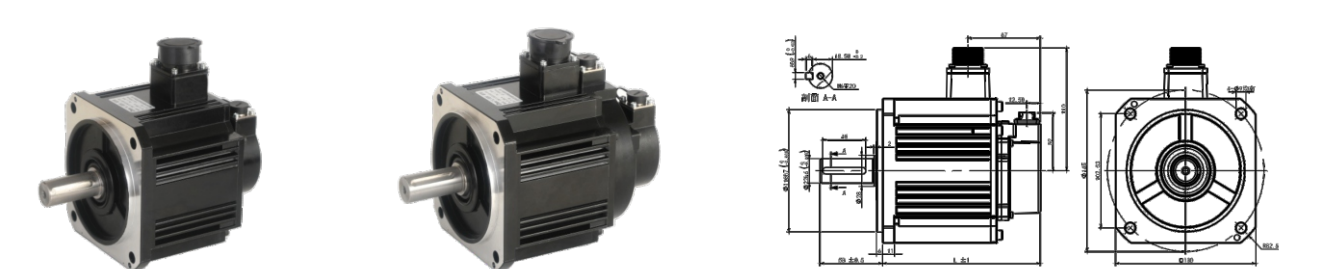

180 Motor dimensions

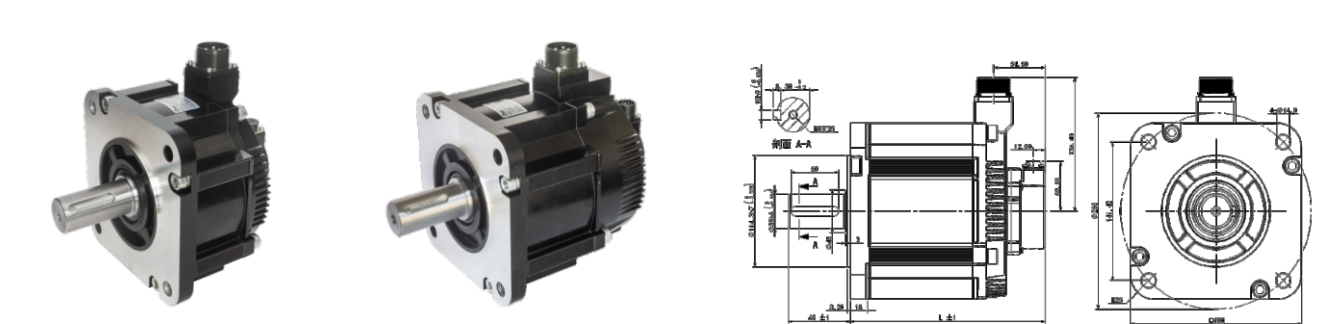

New Energy Products

- PV150A&500 Series Solar Pump Inverter
- PV580 Series IP65 Solar Pump Inverter
- SP500 Series Hybrid Off-Grid Solar Inverter
- SP520 Series Hybrid Off-Grid Solar Inverter



DC 80-450V :
0.4~75KW
DC 230V-800V :
0.75~450KW

Applications

PV150A&500 series supports driving asynchronous water pumps, synchronous water pumps and BLDC, with an efficiency of over 99%, supports DC/AC power input, and can realize automatic switching without battery, automatically sleeps when the light is weak, and automatically resumes work when the light is strong, without manual operation. Under the same conditions, the water output is large.



Solar Pumping System Diagram

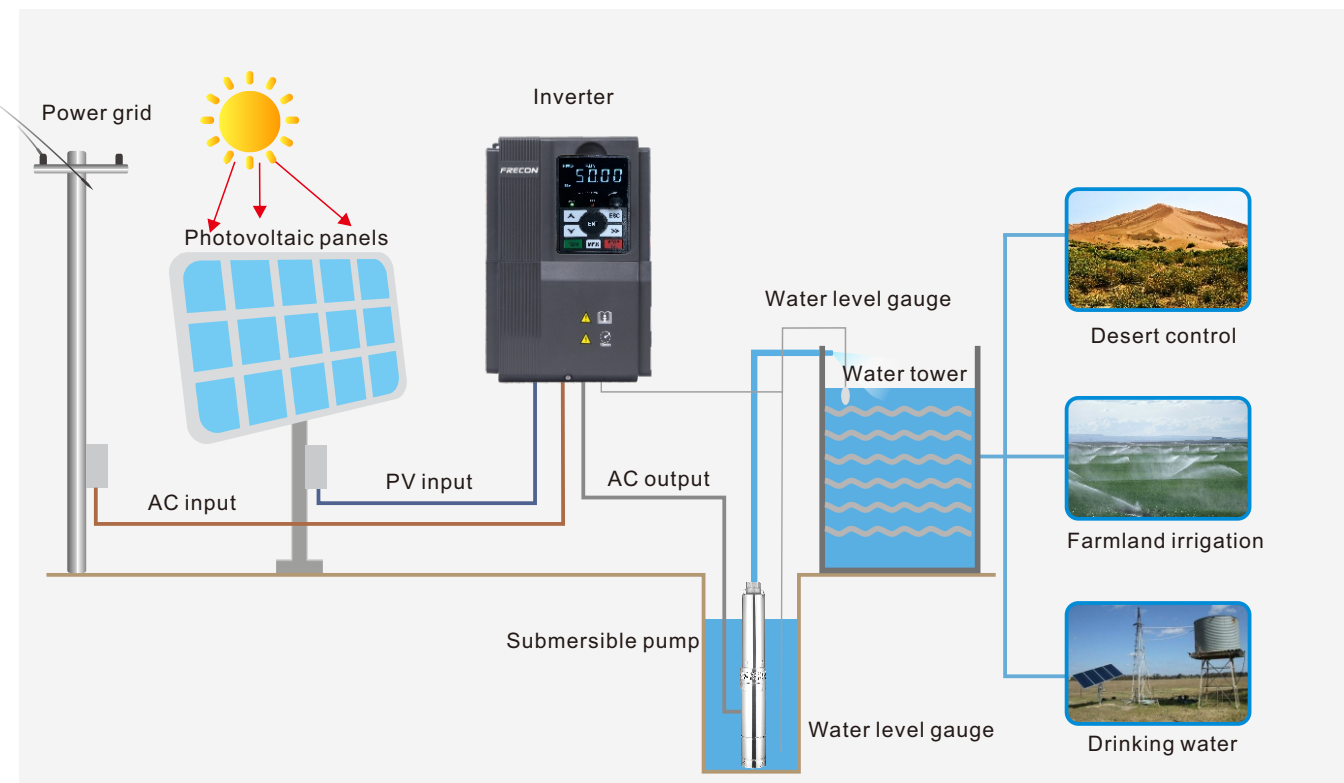

Features

Application

- Applicable to AM, PMSM, BLDC etc.

Hybrid power supply

- Support solar power DC/Power grid AC input, and DC/AC auto switch

Eco-friendly

- Operation without battery

Built-in protection

- Support over-current, over-voltage, phase loss, shortcircuit, over-temperature protection etc.

Dormancy and Wake-up function

- Inverter will entry dormancy mode and wake up automatically according to sunshine intensity

Large water yield

- Larger water yield under same condition

Water level control

- Dry run protection, tank water level control

Advanced MPPT algorithms

- Efficiency reaches 99%

Recording functions

- Recording for total power generated (Kw/h), waterflow(m3), and operation time(H)

Technical Specification

Model	Rated Output Current (A)	Maximum DC Input Current(A)	DC Input Voltage Range(V)	Recommended Solar Power (KW)	Recommended Solar Open Circuit Voltage(VOC)	Pump Power(kW)
PV150I-2S: Input 70-450V DC, single-phase 220V (-15%~20%) AC; output single-phase 220V AC						
PV150I-2S-0.7B-H	7.5	10.6	70-450	1.0	360-430	0.75
PV150I-2S-1.5B-H	10.5	10.6	70-450	2.0	360-430	1.5
PV150I-2S-2.2B-H	17	21.1	70-450	2.9	360-430	2.2
PV150I-2S-4.0B-H	25	31.7	70-450	5.2	360-430	4.0
PV150I-2S-5.5B-H	32	42.2	70-450	7.2	360-430	5.5
PV150A-1S: Input 70-450V DC, single-phase 110-220V AC; output three-phase 110V AC						
PV150A-1S-1.5B-H	7.5	10.6	70-450	0.6	170-300	0.4
PV150A-1S-2.2B-H	9.5	10.6	70-450	1.0	170-300	0.75
PV150A-2S: Input 70-450V DC, single-phase 220V (-15%~20%) AC; output three-phase 220V AC						
PV150A-2S-0.4B-H	2.5	10.6	70-450	0.6	360-430	0.4
PV150A-2S-0.7B-H	4.2	10.6	70-450	1.0	360-430	0.75
PV150A-2S-1.5B-H	7.5	10.6	70-450	2.0	360-430	1.5
PV150A-2S-2.2B-H	9.5	10.6	70-450	2.9	360-430	2.2
4T: input 230-800V DC, three-phase 380V (-15%~30%) AC; output three-phase 380V AC						
PV150A-4T-0.7B-H	2.5	10.6	230-800	1.0	600-750	0.75
PV150A-4T-1.5B-H	4.2	10.6	230-800	2.0	600-750	1.5
PV150A-4T-2.2B-H	5.5	10.6	230-800	2.9	600-750	2.2
PV500-4T-4.0B-H	9.5	10.6	230-800	5.2	600-750	4.0
PV500-4T-5.5B-H	13	21.1	230-800	7.2	600-750	5.5
PV500-4T-7.5B-H	17	21.1	230-800	9.8	600-750	7.5
PV500-4T-011B-H	25	31.7	230-800	14.3	600-750	11
PV500-4T-015B-H	32	42.2	230-800	19.5	600-750	15
PV500-4T-018B-H	37	52.8	230-800	24.1	600-750	18.5
PV500-4T-022B-H	45	63.4	230-800	28.6	600-750	22
PV500-4T-030B-H	60	95.0	230-800	39.0	600-750	30
PV500-4T-037-H	75	116.2	230-800	48.1	600-750	37
PV500-4T-045-H	91	137.3	230-800	58.5	600-750	45
PV500-4T-055-H	112	169.0	230-800	71.5	600-750	55
PV500-4T-075-H	150	232.3	230-800	97.5	600-750	75
PV500-4T-090-H	176	274.6	230-800	117.0	600-750	90
PV500-4T-110-H	210	337.9	230-800	143.0	600-750	110
PV500-4T-132-H	253	401.3	230-800	171.6	600-750	132
PV500-4T-160-H	304	485.8	230-800	208.0	600-750	160
PV500-4T-185-H	350	559.7	230-800	240.5	600-750	185

Note:1.PV500 can customize 900V DC input
2. For parameters above 185kW, please refer to the manual



PV580 Series IP65 Solar Pump Inverter



DC 80-450V :
0.4~3.0KW
DC 230V-800V :
2.2~55KW

Applications

PV580 mainly solves problems such as agricultural irrigation, daily water use, and desert control in areas without electricity and water shortages. It is widely used in various AC asynchronous water pumps and synchronous water pumps. Fully automatic unattended operation, with perfect over-current, over-voltage, output phase loss protection, short circuit, overheating and other protection functions.



Solar Pump System Diagram

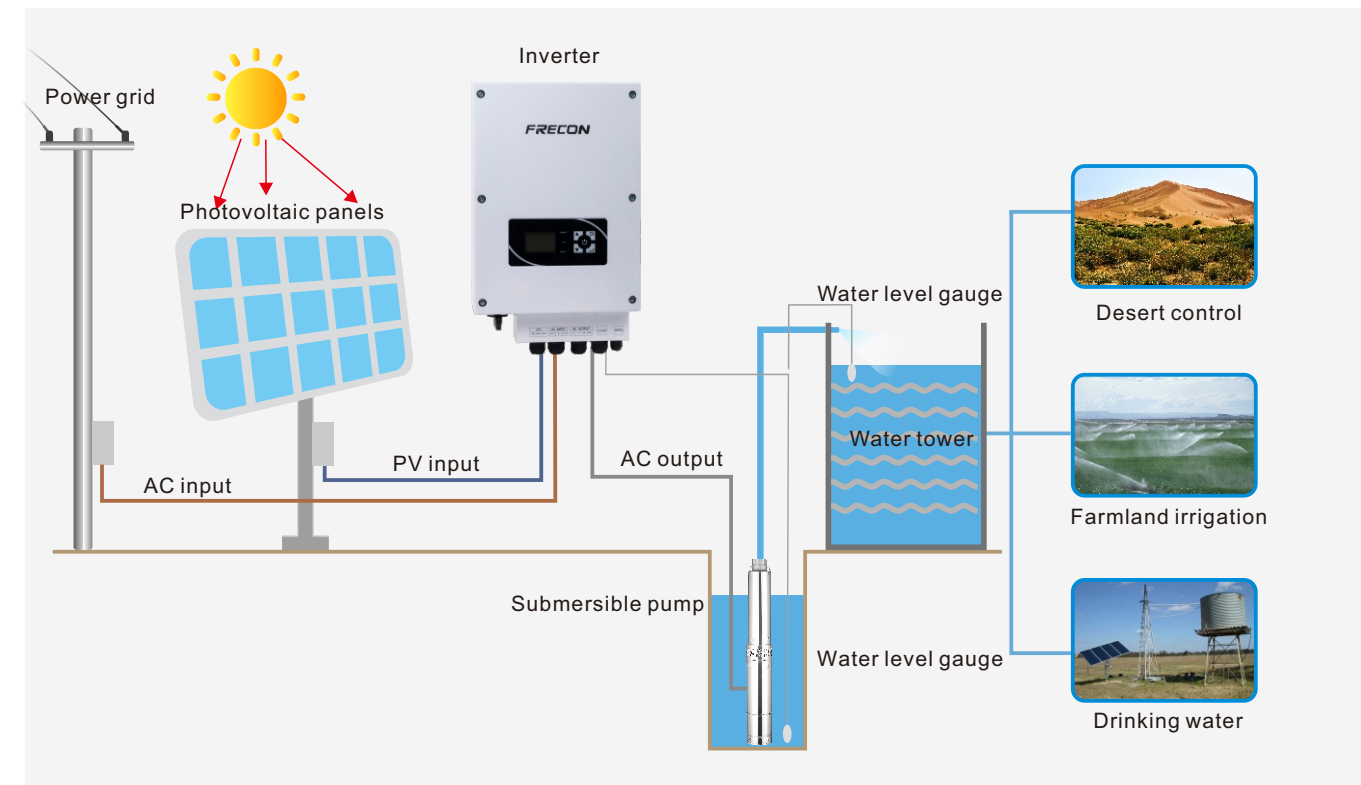

Features

- Fashion design, easy operation
- IP65 design, outdoor installation
- Natural cooling method, low noise
- Compatible with DC / AC power input
- Excellent performance, large water yield
- Built-in start-stop button, operation easily
- Operating temperature range: - 25 ~ 60 °C
- Optimized MPPT algorithm, efficiency> 99%
- Widely used in various AC asynchronous and synchronous pumps
- Supports over-voltage, phase loss, short circuit, over-temperature and etc. protection
- Models below 2.2kW are built-in DC boost module for lower DC voltage input to reduce quantity of solar panel
- All models can be configured with GPRS module (Optional) for real-time remote monitoring and operation in mobile APP

Technical Specification

Product Number	PV580-4T-011-H	PV580-4T-015-H	PV580-4T-018-H	PV580-4T-022-H	PV580-4T-030-H	PV580-4T-037-H	PV580-4T-045-H	PV580-4T-055-H
Photovoltaic Input								
Maximum DC Input	900V							
Recommended MPPT Voltage Range	450V-850V							
Maximum DC Input Current	37A	48A	55A	67A	90A	112A	136A	168A
MPPT Maximum Efficiency	>99%							
Input Channels	1							
Mains/generator Input								
Voltage	360-460Vac (3PH)							
Frequency	50Hz/60Hz (±3%)							
AC Output								
Maximum Matching Motor Power	11kW	15kW	18.5kW	22kW	30kW	37kW	45kW	55kW
Rated Output Voltage	380-460Vac (3PH)							
Output Frequency Range	0-50/60Hz							
Rated Output Current	25A	32A	37A	45A	60A	75A	91A	112A
System								
Degree Of Protection	IP65							
Operating Ambient Temperature Range	-25-60°C							
Cooling Method	Forced air cooling							
Monitor	LCD							
Communication	RS485/GPRS							
Altitude	3000 meters, derating operation above 3000 meters							
Noise	<50dB							
Standards Compliant	En50178 IEC/EN62109-1 IEC61800							
Dimensions	340*539*187(W*H*D)mm				520*550*240(W*H*D)mm			
Package	450*650*305(W*H*D)mm				550*830*387(W*H*D)mm			
Net Weight/Gross Weight (Kg)	19.8/22.6				33.7/37.3			

Technical Specification

Product number	PV580-2S-0.4-H	PV580-2S-0.7-H	PV580-2S-1.5-H	PV580-2S-2.2-H	PV580-2S-3.0-H
Photovoltaic Input					
Maximum DC Input	450V				
Recommended MPPT Voltage Range	100V-400V				
Maximum DC Input Current	15A	15A	30A	30A	30A
MPPT Maximum Efficiency	>99%				
Input Channels	1				
Mains/Generator Input					
Voltage	200-260Vac (1PH)				
Frequency	50Hz/60Hz (±3%)				
AC Output					
Maximum Matching Motor Power	0.4kW	0.7kW	1.5kW	2.2kW	3.0kW
Rated Output Voltage	220/230Vac(1PH or 3PH)				
Output Frequency Range	0-50/60Hz				
Rated Output Current (Single Phase)	4.2A	7.5A	10.5A	15A	17A
Rated Output Current (Three-Phase)	2.5A	4.2A	7.5A	9.5A	13A
System					
Degree Of Protection	IP65				
Operating Ambient Temperature Range	-25-60°C				
Cooling Method	natural cooling				
Monitor	LCD				
Communication	RS485/GPRS				
Altitude	3000 meters, derating operation above 3000 meters				
Noise	<50dB				
Standards Compliant	En50178 IEC/EN62109-1 IEC61800				
Dimensions	280*440*150 (W*H*D) mm				
Package Size	360*520*233 (W*H*D) mm				
Net Weight/Gross Weight (Kg)	11.4/12.6				

New Energy

New Energy



SP500 Series Hybrid Off-Grid Solar Inverter



DC 60~400V :
1.2KW~2.4KW

Applications

The SP500 series is a pure sine solar inverter with a built-in 60-400V MPPT photovoltaic controller, compatible with mains or generator power, configurable AC solar charger priority, and complete short circuit protection, overvoltage protection, overload protection, etc.



Working Principle

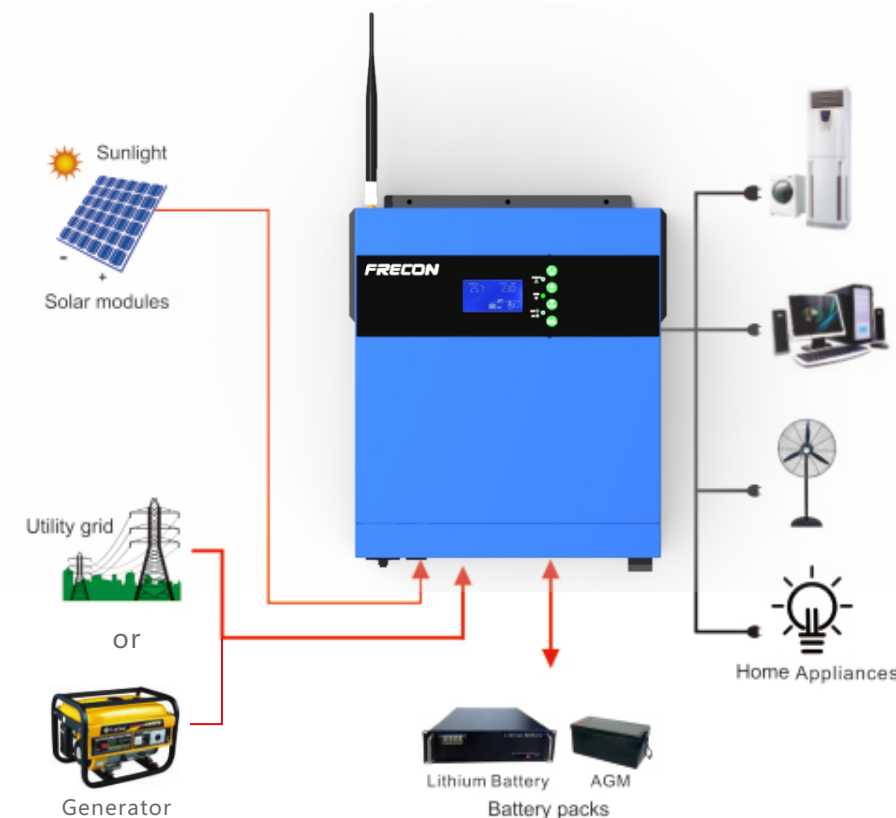

Features

- **1.Support BMS battery management system:**
Standard BMS battery management system communication interface, intelligent battery charging design to improve battery life.
- **2.Easy-to-control LCD panel:**
Users can set the system parameters through the LCD panel at any time to improve the performance of the inverter.
- **3.Support USB upload/download function:**
Standard USB interface, convenient for data upload/download.
- **4.Support mobile phone APP to monitor the inverter:**
Standard Bluetooth, optional WIFI/GPRS module, monitor and control the inverter through the mobile phone APP.
- **5.Small size and light weight:**
Compared with peers with the same power, SP500 inverter has smaller volume and weight, and is more convenient to install.
- **6.High conversion efficiency:**
The conversion efficiency is as high as 98.7%, which is in the leading position compared with the peers.

Technical Parameters

Model	SP500-1200-12H-H	SP500-2400-24H-H	
Line Mode			
Nominal AC Input Voltage/Waveform	230Vac/sine wave (utility or generator)		
AC Input Range	90~280Vac (household appliances); 170Vac~280Vac (uninterruptible power supply)		
Max AC input Voltage	300Vac		
Nominal Input Frequency	50Hz/60Hz (automatic detection)		
AC Input Frequency Range	40~65±1Hz; (>42 or <63+1Hz return)		
Output Short Circuit Protection	breaker		
Efficiency (Line Mode)	>95% (Rated Rload, fully charged battery)		
Transfer Time	10ms typical (UPS)		
	20ms typical (appliance)		
Utility Charging Mode			
Charging Algorithm	3 steps		
AC Charging Current (max)	60Amp (@VI/P=230Vac)	60Amp (@VI/P=230Vac)	
Batch Charging Voltage	Flooded Battery	14.6Vdc	29.2Vdc
	AGM/Gel Battery	14.1Vdc	28.2Vdc
Floating Charging Voltage	13.5Vdc	27Vdc	
Invert Mode			
Rated Output Power	1.5KVA/1.2KW	3KVA/2.4KW	
Output Voltage Waveform	pure sine wave		
Output Voltage/Frequency	230Vac±5%/50Hz		
Peak Efficiency	94%		
Overload Protection	5s@≥150% load; 10s@110%~150% load		
Surge Capacity	2*rated power for 5 seconds		
Nominal Battery Input Voltage	12Vdc	24Vdc	
Cold Start Voltage	11.5Vdc	23.0Vdc	
High DC Cut-Off Voltage	15.5Vdc	31Vdc	
No-Load Power Consumption	<25W	<30W	
MPPT Solar Charging And Inverter Mode			
Maximum Photovoltaic Array Power	2000w	3000w	
PV Array MPPT Voltage Range	60~400Vdc		
Maximum Photovoltaic Array Open Circuit Voltage	350Vdc		
Maximum Charging Current	60 amps		
Other Information			
Safety Certificate	CE certification		
Humidity	5% to 95% relative humidity (noncondensing)		
Operating Temperature Range	-10°C ~ 50°C		
Storage Temperature	-15°C~60°C		
Enclosure	IP21		
Dimensions D*W*H(mm)	110x260x355	110x260x355	
Net Weight (Kg)	5.2	5.5	



Applications

SP520 series are pure sine solar inverters, built-in 120-495V MPPT photovoltaic controller, support battery-free start, compatible with mains or generator power configurable AC/solar charger priority, with complete short-circuit protection, over-under Voltage protection, overload protection, etc.



New Energy

New Energy

Features

➤ Solar power and grid power the load simultaneously

The inverter supports photovoltaic power and mains to supply power to the load at the same time.

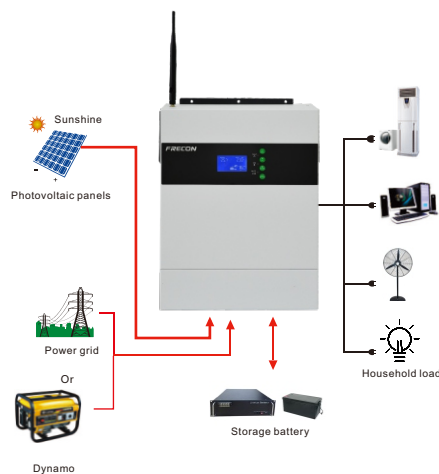

➤ Easy-to-control LCD panel

Users can set the system parameters through the LCD panel at any time to improve the performance of the inverter.

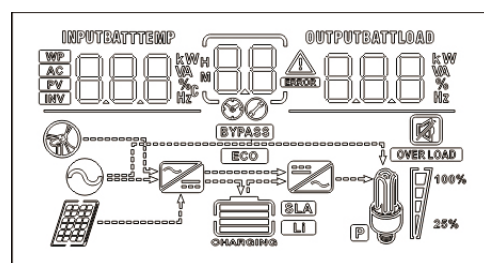

➤ Configurable output source priority

➤ Configurable AC/Solar Charger Priority

➤ With complete short circuit protection, over voltage protection, overload protection, etc.

➤ Support no battery start



➤ Support BMS battery management system

Standard BMS battery management system communication interface, Smart battery charging design improves battery life

➤ Support mobile phone APP to monitor the inverter

Standard WIFI module, monitor and control the inverter through mobile APP

Technical Parameters

Model	SP520-3500-24H-H	SP520-5500-48H-H
Rated Power	3500VA	5500VA
AC Input		
Rated Input Current	220/230/240VAC	
Working Voltage Range	170-280VAC (personal computer); 90-280VAC (household appliances)	
Frequency	50Hz/60Hz (automatic detection)	
Output		
Rated Output Voltage (Vac)	220/230/240VAC	
Surge Power	6000VA	10000VA
Efficiency (Peak)	94%	
Conversion Time	10ms (personal computer); 20ms for household appliances	
Battery And AC Input Charging Specifications		
Battery Voltage	24VDC	48VDC
Float Voltage	27VDC	54VDC
Overcharge Protection	33VDC	63VDC
Maximum Charging Current	80A	80A
Solar Charging Specifications		
Maximum PV DC Input Power	4000W	5000W
MPPT Working Voltage Range	120-450VDC	120-450VDC
Maximum PV Open Circuit Voltage	495VDC	495VDC
Maximum Charging Current	100A	
Physical Specifications		
Dimensions D*W*H(mm)	120*322*416	
Net Weight (Kg)	9	10
Communication Interface	RS232/WiFi	
Working Environment		
Humidity	5%-95% relative humidity (no frost)	
Operating Temperature	-10°C~50°C	
Storage Temperature	-15°C~60°C	



PL10 Series PLC



Various starting methods

Voltage ramp current limit start;
Current limit start;
jog;

Two parking options

free parking;
soft parking;

Perfect protection function

Phase loss, starting overcurrent, starting overload, A variety of comprehensive protection functions such as startup timeout.

Fault memory function

It is convenient for users to analyze the cause and troubleshoot.

Applications

PL10 is a miniature PLC launched by our company. It is a simple motion programmable controller with 4 pulse outputs. Beverage, packaging, plastic steel, construction machinery, air conditioners, elevators, printing and other machine manufacturing industries.

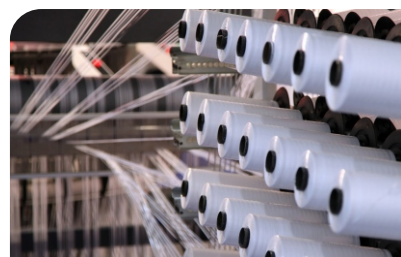

Product Nameplate Description

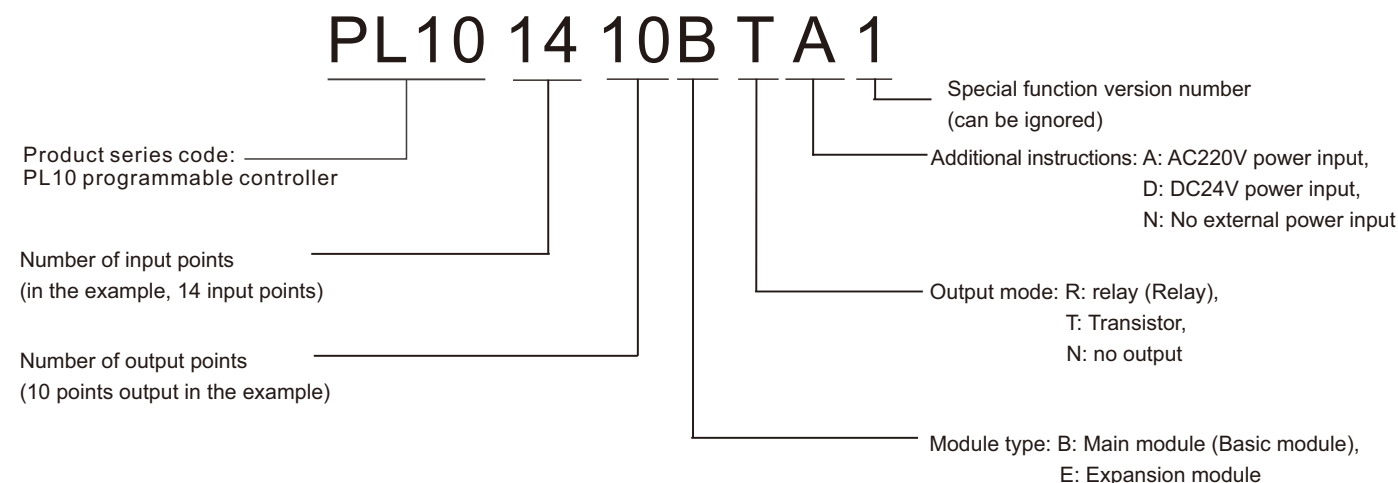

Features

Small model, high configuration, large capacity, high speed

The integrated analog input and output program capacity reaches 12K, The basic instruction only needs 0.3μs, and can be expanded to 4 modules

Abundant interrupt resources

Support communication interruption, pulse interruption, power failure interruption, And can set the interrupt priority to achieve advanced control

Flexible programming

Support MODBUS network, handheld computer, Three editing modes of remote dialing, convenient for maintenance and debugging

Convenient and practical features

Provide special function module configuration, inverter communication instructions, Simplify complex programming Provide system configuration verification tools to facilitate users to expand configuration

Safer, more stable and more reliable

8-digit password protection, which can be set to prohibit uploading of programs to prevent unauthorized copying, ultra-wide voltage design, three-proof processing, input filtering and power-off protection functions to ensure that the PLC is more stable and reliable

Strong communication networking capabilities

Support PLbus N:N network communication protocol, support OPC service, provide PROFIBUS-DP slave station communication simulation

Powerful positioning and high-speed processing capabilities

Positioning instructions to realize the position control of machinery and equipment. Variable-speed pulse output, including line pulse output function, realizes multi-stage variable speed control of servo or stepping motor Built-in high-speed processing: 6-way high-speed pulse input, maximum frequency 50KHz; 2-way 100KHz high-speed pulse output

Technical Parameters

Project		Specification
Implementation Modalities		Cyclic scanning + interrupt mode
Programmatically		Instructions, Ladder Diagram, Sequential Function Chart
Command Type	Basic Instructions	32 items
	Application Instruction	226 items
Execution Time	Basic Instructions	0.3μs
	Application Instruction	Several μs~hundreds of μs
Program Capacity		12K steps
Maximum Expansion		4 expansion modules, including I/O expansion and special function modules
Input Relay (X)		X0~X177, 128 points, octal code
Output Relay (Y)		Y0~X177, 128 points, octal code
Auxiliary Relay (M)		M0~M2047, 2048 points
Local Auxiliary Relay (LM)		LM0~LM63, 64 points
Special Auxiliary Relay (SM)		SM0~SM255,256 points
Status Relay (S)		S0~S1023,1024 points
Timer (T)	256 points (T0~T255)	100ms precision: T0~T299, 210 pieces
		10ms accuracy: T210~T251, 42 pieces
		1ms precision: T252~T255, 4 pieces
Timer (S)	256 points (C0~C255)	16-bit count up: C0~C199, 200
		32-bit up/down counting: C200~C235, 36
		32-bit high-speed counting: C236~C255, 20
Data Register (D)		D0~D7999,8000 points
Local Data Register (V)		V0~V63,64 points
Index Addressing Register (Z)		Z0~Z15,16 points
Special Data Register (SD)		SD0~SD255,256 points
Hold Function		Can save M, S, D, C elements, 320 bit elements, 180 word elements
Storage Medium		EEPROM+FLASH
High Speed Counter		Single phase: 6 groups, 2x50KHz+4x10KHz Bi-phase: 2 groups, 1x30KHz+1x5KHz
Pulse Output		Y0~Y1, two independent 100KHz output
Interrupt Resource	External Input Interrupt	16 (X0~X7, 8 channels support rising and falling edges)
	High-Speed Counting Interrupt	6
	Timed Interrupt	3
	Communication Interruption	8
	Pulse Break	2
	Power Outage	1
Analog Potentiometer Input		2 items (0~255)
Pulse Catch		8 channels, X0-X1: 20μs, X2-X7: 100μs
Digital Filtering		X0-X7 provide digital filtering, filtering time (ms) 0, 8, 16, 32, 64. Other hardware filtering
Communication Port		X0-X7 provide digital filtering, filtering time (ms) 0, 8, 16, 32, 64. Other hardware filtering

Selection table

Main module

Product Series	Product number	Description	Product Size
PL10	PL10-1006BRA	PL10 series 10-point input 6-point relay output main module (AC power supply)	135 x 90 x 75
PL10	PL10-1006BTA	PL10 series 10-point input 6-point transistor output main module (AC power supply)	135 x 90 x 75
PL10	PL10-1410BRA	PL10 series 14-point input and 10-point relay output main module (AC power supply)	135 x 90 x 75
PL10	PL10-1410BTA	PL10 series 14-point input and 10-point transistor output main module (AC power supply)	135 x 90 x 75
PL10	PL10-1614BRA	PL10 series 16-point input and 14-point relay output main module (AC power supply)	150 x 90 x 75
PL10	PL10-1614BTA	PL10 series 16-point input and 14-point transistor output main module (AC power supply)	150 x 90 x 75
PL10	PL10-1614BRA1	16-point input and 14-point relay output master module with integrated 2-in 1-out analog function (AC power supply)	182 x 90 x 75
PL10	PL10-1614BTA1	16-point input and 14-point transistor output main module with integrated 2-in 1-out analog function (AC power supply)	182 x 90 x 75
PL10	PL10-2416BRA	PL10 series 24-point input 16-point relay output main module (AC power supply)	182 x 90 x 75
PL10	PL10-2416BTA	PL10 series 24-point input and 16-point transistor output main module (AC power supply)	182 x 90 x 75
PL10	PL10-3624BRA	PL10 series 36-point input 24-point relay output main module (AC power supply)	224.5 x 90 x 75
PL10	PL10-3624BTA	PL10 series 36-point input 24-point transistor output main module (AC power supply)	224.5 x 90 x 75

I/O extension module

Product Series	Product Number	Description	Product Size
PL10	PL10-0808ERN	PL10 series 8-point input 8-point relay output expansion module	61 x 90 x 75
PL10	PL10-0808ETN	PL10 series 8 points input 8 -point transistor output expansion module	61 x 90 x 75
PL10	PL10-1600ENN	PL10 series 16 -point input expansion module	61 x 90 x 75
PL10	PL10-0016ETN	PL10 series 16 -point transistor output expansion module	61 x 90 x 75
PL10	PL10-0016ERN	PL10 series 16 -point relay output expansion module	61 x 90 x 75

Special function module

Product Series	Product Number	Description	Product Size
PL10	PL10-4AD	PL10 series 4 point analog input module	61 x 90 x 75
PL10	PL10-4DA	PL10 series 4 -point simulation output module	61 x 90 x 75
PL10	PL10-4TC	PL10 series 4 -point thermocotometer module	61 x 90 x 75
PL10	PL10-4PT	PL10 series 4 -point thermal resistance module	61 x 90 x 75
PL10	PL10-5AM	PL10 series 4 -point analog input, 1 point analog output	61 x 90 x 75

PL10 Series

PL10 Series



HK Series HMI

High -performance processor

Industrial -grade high -performance RISC 32BIT processor, The main frequency reaches 400MHz

High -capacity Flash

Support the storage of large -capacity data, not lost power off power, Support U disk and SD card storage

Online simulation

Use a computer to directly connect PLC to simulate Configuration project, can get data from PLC

U disk guide

Support U disk update project
Support U disk update formula
Data that supports the U disk import and export

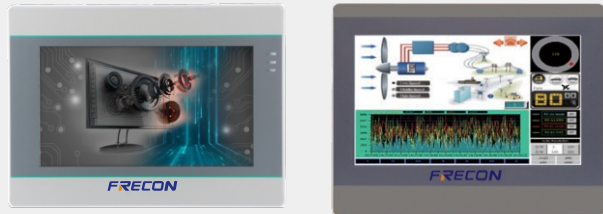

Applications

The HK series touch screen is a high -performance embedded integrated touch screen with industrial-grade high -performance RISC 32BIT processors as its core. The product design uses high brightness TFT liquid crystal. With powerful image display and data processing functions.

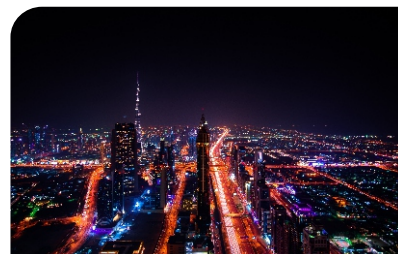
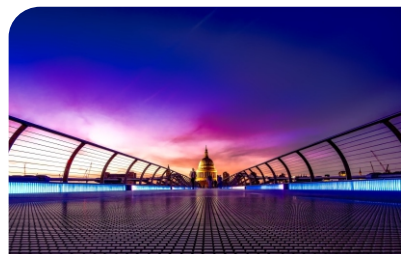

Model Specification

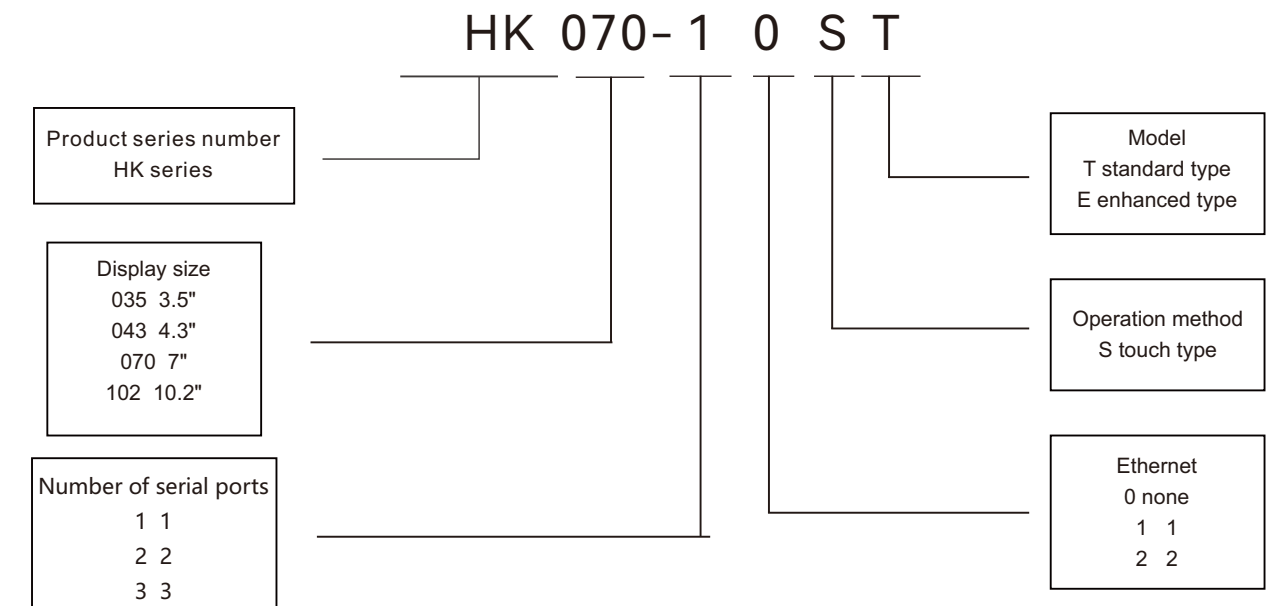

Features

High -performance processor

- Industrial -grade high -performance RISC 32BIT processor, The main frequency reaches 400MHz

High -capacity Flash

- Support the storage of large -capacity data, not lost power off power, Support U disk and SD card storage

Gallery

- Provide a lot of rich, for vector gallery for various industries
- Support customized vector graphics, which can be painted by yourself
- Support picture formats such as BMP, JPG as gallery graphics

Text font

- Support True Type (TTF) font
- Font editing function that supports complex margin
- Unicode encoding, international standards

Online simulation

- Use a computer to directly connect PLC to simulate the configuration project, You can get data from PLC

Macro command programming

- Support C language script
- Support self -setting function library
- Support free portal communication protocol
- Support C standard mathematical computing function
- Multiple execution methods

U disk guide

- Support U disk update project
- Data that supports the U disk import and export
- Support U disk update formula

HMI Technical Parameters

HK Series

							
Model	HK102-20SE	HK102-10ST	HK070-20SE	HK070-10ST	HK043-20SE	HK043-20ST	
Resolution	800x480		800x480		480x272		
Display Type	TFT color touch screen (LED), 65536 color						
Backlight Life	50000Hours						
LCD Screen Brightness (CD/M2)	300						
Touch Panel	4 wire resistance type						
CPU	32 bits 400MHz RISC						
Battery Memory	256KB						
Data Memory	128M FLASH + 64M DDRAM						
Clock	Have						
USB	USB Host + USB Client						
Serial Port	COM1	RS232/RS422/RS485				RS422/RS485	
	COM2	RS232/RS485	-	RS232/RS485	-	RS232	
	COM3	COM3 Optional	-	COM3 Optional	-	-	
Ethernet	None						
Input Voltage	DC24V (12~28VDC)						
Power Consumption	<8W		<8W		<5W		
Operating Temperature	-10°C~60°C						
Authentication	FCC Part 15 Class A & EN61000-6-2,EN61000-6-4(CE)						
Panel Protection Level	IP65						
Panel Size (mm)	272.0x190.5x47.4		201.0x146.0x36.0		138.0x86.0x37.0 142.0x86.0x30.3		
Open Hole Size (mm)	260.0x179.0		192.0x138.0		131.0x79.0 131.0x78.0		
Net Weight/Mao Heavy (Kg)	1.2/1.7		0.6/1.0		0.3/0.6		



RQ100(A) Series Digital Soft Starter



- Multi mode starting**
 Voltage Ramp current limit starting
 Current limit starting Inching
- Two types of braking**
 Free stop
 Soft stop
- Perfect protection functions**
 Default phase, starting over current, starting overload, starting timeout protection and many other comprehensive protection functions.
- Fault memory function**
 Easy for user analyzing and debugging

Applications

Products are widely used on motor transmission device in metallurgy, oil, firefighting, mine, petrochemical, and other industrial fields. An ideal replacement of traditional star/triangle transformation, self-coupled step-down, magnetic control step-down starting equipment etc.



Overall Dimensions And Install Dimensions

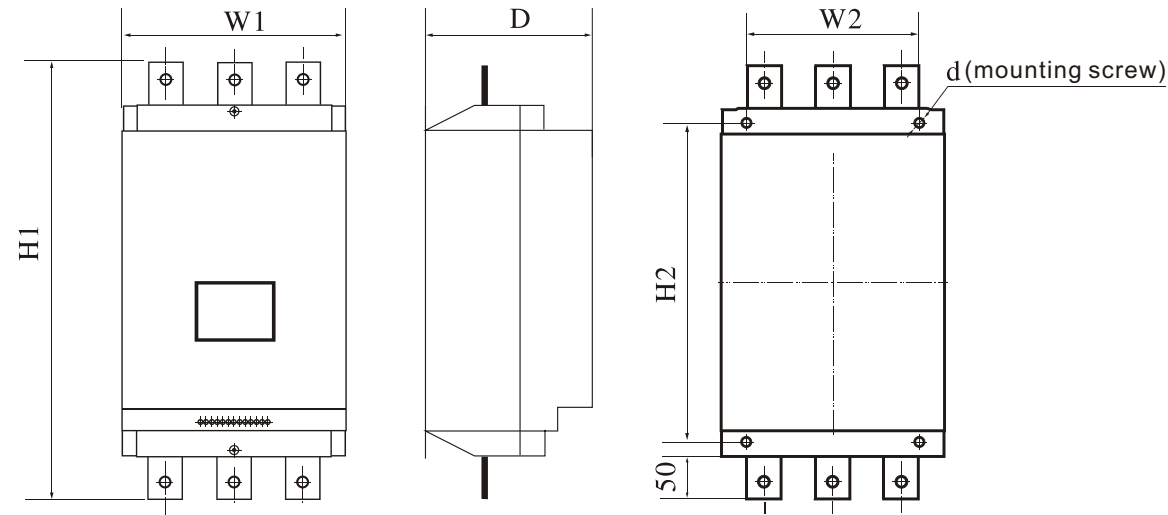

Model No.	Rated Power (kW)	Rated Current (A)	Overall Dimensions (mm)			Install Dimensions (mm)			Net Weight (kg)
			W1	H1	D	W2	H2	D	
RQ100-5R5A-3-H	5.5	11	204	330	239	117	303	7	<6.5
RQ100-7R5A-3-H	7.5	15	204	330	239	117	303	7	<6.5
RQ100-011A-3-H	11	23	204	330	239	117	303	7	<6.5
RQ100-015A-3-H	15	30	204	330	239	117	303	7	<6.5
RQ100-018A-3-H	18.5	37	204	330	239	117	303	7	<6.5
RQ100-022A-3-H	22	45	204	330	239	117	303	7	<6.5
RQ100-030A-3-H	30	60	204	330	239	117	303	7	<7.5
RQ100-037A-3-H	37	75	204	330	239	117	303	7	<7.5
RQ100-045A-3-H	45	90	204	330	239	117	303	7	<7.5
RQ100-055A-3-H	55	110	214	431	263	150	398	11	<8.5
RQ100-075A-3-H	75	150	214	431	263	150	398	11	<11
RQ100-090A-3-H	90	180	275	563	254	201	511	11	<20
RQ100-115A-3-H	115	230	275	563	254	201	511	11	<20
RQ100-132A-3-H	132	265	275	563	254	201	511	11	<22
RQ100-160A-3-H	160	320	275	563	254	201	511	11	<22
RQ100-185A-3-H	185	370	275	563	254	201	511	11	<22
RQ100-200A-3-H	200	400	275	563	254	201	511	11	<30
RQ100-220A-3-H	220	440	307	620	279	233	563	11	<30
RQ100-250A-3-H	250	500	307	620	279	233	563	11	<30
RQ100-280A-3-H	280	560	307	620	279	233	563	11	<30





- ⦿ **Three starting modes:**
 Voltage Ramp
 Current limit
 Jogging
- ⦿ **Two types of braking**
 Free stop
 Soft stop
- ⦿ **Perfect protection functions**
 Default phase, three-phase imbalance, starting over current, running overload, short circuit, overheating, starting timeout protection and many other comprehensive protection functions.
- ⦿ **Analog output function:**
 4-20 mA analog output interface
- ⦿ **Rated output can be set**
Programmable relay output:
 Fault, preparation, start, run and other state programmable output

Applications

Products are widely used on motor transmission device in metallurgy, oil, firefighting, mine, petrochemical, and other industrial fields. An ideal replacement of traditional star/triangle transformation, self-coupled step-down, magnetic control step-down starting equipment etc.



RQ Series Digital Soft Starter

RQ Series Digital Soft Starter

Overall Dimensions And Install Dimensions

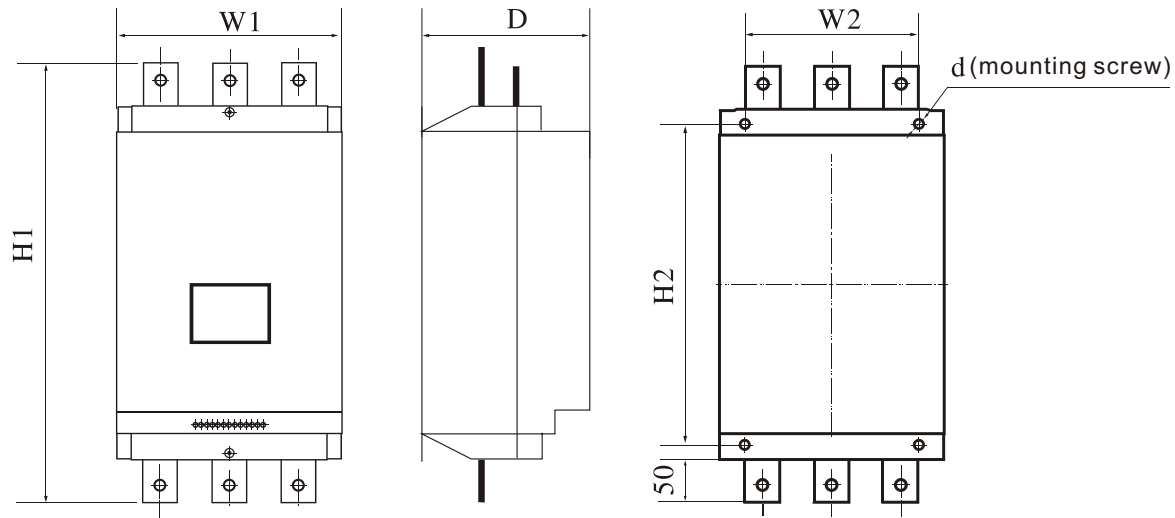

Model No.	Rated Power (KW)	Rated Current (A)	Overall Dimensions (mm)			Install Dimensions (mm)			Net Weight (kg)
			W1	H1	D	W2	H2	D	
RQ100-5R5B-3-H	5.5	11	170	302	219	144	263	7	6.5
RQ100-7R5B-3-H	7.5	15	170	302	219	144	263	7	< 6.5
RQ100-011B-3-H	11	23	170	302	219	144	263	7	< 6.5
RQ100-015B-3-H	15	30	170	302	219	144	263	7	< 6.5
RQ100-018B-3-H	18.5	37	170	302	219	144	263	7	< 6.5
RQ100-022B-3-H	22	43	170	302	219	144	263	7	< 6.5
RQ100-030B-3-H	30	60	170	302	219	144	263	7	< 6.5
RQ100-037B-3-H	37	75	170	302	219	144	263	7	< 6.5
RQ100-045B-3-H	45	90	170	302	219	144	263	7	< 6.5
RQ100-055B-3-H	55	110	170	302	219	144	263	7	< 6.5
RQ100-075B-3-H	75	150	170	302	219	144	263	7	< 11
RQ100-090B-3-H	90	180	260	470	203	190	440	9	< 11
RQ100-115B-3-H	115	230	260	470	203	190	440	9	< 22
RQ100-132B-3-H	132	265	260	470	203	190	440	9	< 22
RQ100-160B-3-H	160	320	260	470	203	190	440	9	< 22
RQ100-185B-3-H	185	370	260	470	203	190	440	9	< 22
RQ100-200B-3-H	200	400	260	470	203	190	440	9	< 22
RQ100-220B-3-H	220	440	260	470	203	190	440	9	< 22
RQ100-250B-3-H	250	500	290	590	240	212	470	9	< 30
RQ100-280B-3-H	280	560	290	590	240	212	470	9	< 30
RQ100-320B-3-H	320	640	290	590	240	212	470	9	< 30
RQ100-355B-3-H	355	700	290	590	240	212	470	9	< 40
RQ100-400B-3-H	400	800	290	590	240	212	470	9	< 40
RQ100-450B-3-H	450	900	290	590	240	212	470	9	< 40
RQ100-500B-3-H	500	1000	290	590	240	212	470	9	< 40

Optional Accessories



Reactor

Inverter Power	Input Reactor	Output Reactor
2.2kw	ACL-4T-2.2	OCL-4T-2.2
4.0kw	ACL-4T-4.0	OCL-4T-4.0
5.5kw	ACL-4T-5.5	OCL-4T-5.5
7.5kw	ACL-4T-7.5	OCL-4T-7.5
11kw	ACL-4T-011	OCL-4T-011
15kw	ACL-4T-015	OCL-4T-015
18.5kw	ACL-4T-018	OCL-4T-018
22kw	ACL-4T-022	OCL-4T-022
30kw	ACL-4T-030	OCL-4T-030
37kw	ACL-4T-037	OCL-4T-037
45kw	ACL-4T-045	OCL-4T-045
55kw	ACL-4T-055	OCL-4T-055
75kw	ACL-4T-075	OCL-4T-075
90kw	ACL-4T-090	OCL-4T-090
110kw	ACL-4T-110	OCL-4T-110
132kw	ACL-4T-132	OCL-4T-132
160kw	ACL-4T-160	OCL-4T-160
185kw	ACL-4T-185	OCL-4T-185
200kw	ACL-4T-200	OCL-4T-200
220kw	ACL-4T-220	OCL-4T-220
250kw	ACL-4T-250	OCL-4T-250
280kw	ACL-4T-280	OCL-4T-280
315kw	ACL-4T-315	OCL-4T-315
355kw	ACL-4T-355	OCL-4T-355
400kw	ACL-4T-400	OCL-4T-400
450kw	ACL-4T-450	OCL-4T-450
500kw	ACL-4T-500	OCL-4T-500
560kw	ACL-4T-560	OCL-4T-560
630kw	ACL-4T-630	OCL-4T-630

Filter

Inverter Power	Input Filter	Output Filter
0.75kw	FLT-4T-P005	FLT-4T-L005
1.5kw		
2.2kw	FLT-4T-P010	FLT-4T-L010
4.0kw		
5.5kw	FLT-4T-P020	FLT-4T-L020
7.5kw		
11kw	FLT-4T-P036	FLT-4T-L036
15kw		
18.5kw	FLT-4T-P065	FLT-4T-L065
22kw		
30kw		
37kw	FLT-4T-P100	FLT-4T-L100
45kw		
55kw	FLT-4T-P150	FLT-4T-L150
75kw		
90kw	FLT-4T-P250	FLT-4T-L250
110kw		
132kw		
160kw	FLT-4T-P400	FLT-4T-L400
185kw		
200kw		
220kw		
250kw	FLT-4T-P600	FLT-4T-L600
280kw		
315kw		
355kw	FLT-4T-P900	FLT-4T-L900
400kw		
450kw		
500kw	FLT-4T-P1200	FLT-4T-L1200
560kw		
630kw		

Note: After installing the input filter, EMI meets the C2 standard

Optional Accessories

Optional Accessories

Brake Unit ,Brake Resistor.

Voltage Level	Max Applicable Motor Power	Brake Unit	Brake Resistance (ED = 10%, 100%braking torque)	
			Resistance	Quantity
Three -phase 380V	0.75kw	Built -in	360Ω/200W	1
	1.5kw	Built -in	360Ω/200W	1
	2.2kw	Built -in	180Ω/400W	1
	4.0kw	Built -in	180Ω/400W	2
	5.5kw	Built -in	60Ω/1000W	1
	7.5kw	Built -in	60Ω/1000W	1
	11kw	Built -in	30Ω/2000W	1
	15kw	Built -in	30Ω/2000W	1
	18.5kw	Built -in	30Ω/2000W	1
	22kw	Built -in	30Ω/2000W	2
	30kw	Built -in	30Ω/2000W	2
	37kw	Built -in optional or FRBU-4T-045	30Ω/2000W	2
	45kw	Built -in optional or FRBU-4T-045	10Ω/6000w	3
	55kw	Built -in optional or FRBU-4T-045	7.5Ω/8000w	4
	75kw	Built -in optional or FRBU-4T-045	7.5Ω/8000w	4
	90kw	FRBU-4T-132	6.8Ω/20kw	2
	110kw	FRBU-4T-132	6.8Ω/20kw	3
	132kw	FRBU-4T-132	5Ω/25kw	4
	160kw	IPC-DR-3HA	3.5Ω/40kw	4
	185kw	IPC-DR-3HA	3.5Ω/40kw	4
200kw	IPC-DR-4HA	3.2Ω/50kw	5	
220kw	IPC-DR-4HA	3.2Ω/50kw	5	
250kw	IPC-DR-4HA	3.2Ω/50kw	5	
280kw	IPC-DR-5HA	2.6Ω/60kw	6	
315kw	IPC-DR-5HA	2.6Ω/60kw	6	

Optional Cards

Type	Name	Model No.	Function
PG Card	5V differential input incremental encoder interface board	EXC-PG01	1. A+/A-, B+/B-Z+/100 million-pulse input 2. Maximum input frequency: 300KHz 3. Power output for PG: +5V, maximum current 200mA
	12V open collector/Push-pull input incremental encoder interface board	EXC-PG02	1. A, B, Z pulse input 2. Maximum input frequency: 100KHz 3. Power output for PG: +12V, maximum current 200mA
	Rotate transformer PG card (With GD control board)	EXC-PG03B	Provide resolver interface, including excitation signal EXC+/- and feedback signal SIN+/-, COS+/-, 10KHz
	5V UVW incremental encoder	EXC-PG04	Provide ENDAT2.2 type encoder interface
	ECN1313 Encoder (With CY control board)	EXC-PG05	HEIDENHAIN ERN1313 encoder PG card
	ERN1387 sin-cos encoder	EXC-PG06	HEIDENHAIN ERN1387 applicable type 1. Maximum input frequency: 20KHz 2. Power output for PG: +5V, maximum current 200mA
Communication Option Card	PROFIBUS-DP option external modul	EXC-COM01E	It is used for running/stopping the inverter, setting/viewing parameters and various monitoring by communicating with the host controller PROFIBUS-DP
	EtherCAT option external module	EXC-COM03	It is used for running/stopping the inverter, setting/viewing parameters and various monitoring through CANopen communication with the host controller
	MODBUS register adapter module	EXC-COM04E	Used for running/stopping the inverter, setting/checking parameters, and various monitoring by communicating with the host controller DeviceNet
	PROFINET option card	EXC-COM05	Used for running/stopping the inverter, setting/checking parameters, and various monitoring through Ethernet/IP communication with the host controller
	GPRS sending terminal 2G/4G	GPRS sending terminal IOT100	*
Other	Plastic machine expansion card	EXC-PM1	Support two analog inputs, current input range: 0-1A and 0-2A optional
	LCD keyboard	*	Full Chinese, English and Russian display interface and function operation buttons
	Keyboard extension cable	*	Extend the operation keyboard for remote control